

# SPHERICAL BUSHINGS

- Steel-on-steel Spherical Bushings
- Maintenance-free Spherical Bushings



## Structure and Features

IKO Spherical Bushings are self-aligning spherical plain bushings that have inner and outer rings with spherical sliding surfaces, and can take a large radial load and a bi-directional axial load at the same time. There are many types of Spherical Bushings, but they are basically divided into steel-on-steel types and maintenance-free types according to the kind of sliding surfaces.

Steel-on-steel Spherical Bushings have inner and outer rings of high carbon chromium bearing steel, of which sliding surfaces are phosphate-treated and then dry-coated with molybdenum disulfide (MoS<sub>2</sub>). They can, therefore, operate with low torque, and have excellent wear resistance and large load capacity. They are especially suitable for applications where there are alternate loads and shock loads. They have wide applications mainly in industrial and construction machinery.

Maintenance-free Spherical Bushings consist of an outer ring which has a special PTFE liner reinforced with copper alloy meshes on the sliding surface, and a spherical inner ring of which sliding surface has a hard chromium plating. Creep deformation due to compressive load is small, and wear resistance is superior. Thus, they are maintenance-free and can be used for extended periods of time without re-lubrication. They are especially suitable in cases where fixed directional loads are applied and are used mainly in food processing machines and construction machinery and in other applications in which the use of oil is undesirable or lubrication is not possible.

## Types

Spherical Bushings are available in various types shown in Table 1.

Table 1 Type of bearing

Series	Type	Steel-on-steel		Maintenance-free	
		Without seals	With seals	Without seals	With seals
Metric	SB		—	GE ... EC	GE ... EC-2RS
	SB ... A		—		
	GE ... E, ES	GE ... ES-2RS			
	GE ... G, GS	GE ... GS-2RS			
Inch	SBB	SBB ... -2RS	—	—	

### Structures of Spherical Bushings

#### Steel-on-steel type

SB ... A

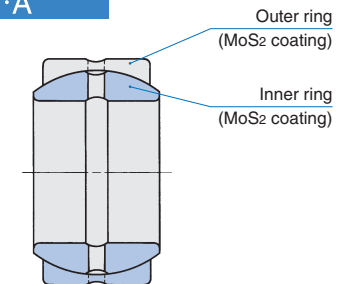

#### Steel-on-steel type

GE ... ES-2RS

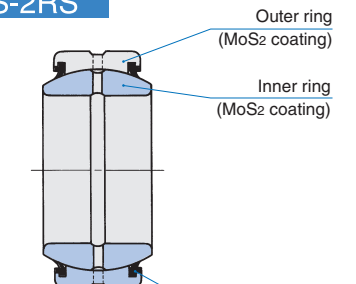

#### Maintenance-free type

GE ... EC

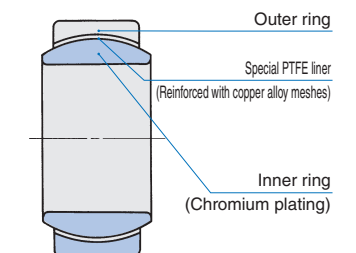

#### Maintenance-free type

GE ... EC-2RS

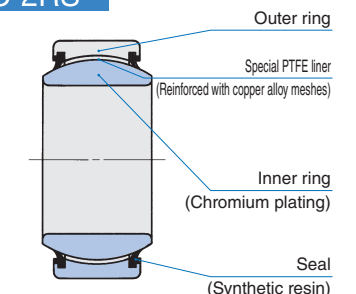

K

SB  
GE  
SBB

### Steel-on-steel Spherical Bushings SB

These bushings have an outer ring split into halves. The split outer ring and the inner ring are held together by a snap ring placed in the groove around the outer periphery of the outer ring.

### Steel-on-steel Spherical Bushings SB...A

These bushings have an outer ring split only at one position, and therefore, the outer and inner rings will not separate. Handling before mounting and mounting to the housing are simple. The boundary dimensions are the same as those of the SB type. Therefore, SB and SB...A types are dimensionally interchangeable, but the radial internal clearances of the SB...A type are smaller than those of the SB type.

### Steel-on-steel Spherical Bushings GE...E, GE...ES

The dimension series of these types conform to ISO standards and they can be used internationally. The outer ring is split at one position. The GE...E and GE...ES types are available. These are classified by bushing size.

The GE...ES type can be provided with seals, which are double-lip type polyurethane seals effective for prevention against grease leakage and dust penetration. The sealed type is indicated by the suffix "-2RS" at the end of the identification number.

### Steel-on-steel Spherical Bushings GE...G, GE...GS

As compared with the GE...E and GE...ES types, these bushings have larger load capacities and larger permissible tilting angles. The dimension series also conform to ISO standards, and they can be used internationally. The outer ring is split at one position. The GE...G and GE...GS types are available. They are classified by bushing size.

The GE...GS type can be provided with seals, which are double-lip type polyurethane seals effective for prevention against grease leakage and dust penetration. The sealed type is indicated by the suffix "-2RS" at the end of the identification number.

### Steel-on-steel Spherical Bushings SBB

These are inch series bushings. The outer ring is split at one position.

These bushings can be provided with seals, which are double-lip type polyurethane seals effective for prevention against grease leakage and dust penetration. The sealed type is indicated by the suffix "-2RS" at the end of the identification number.

### Maintenance-free Spherical Bushings GE...EC

These bushings have the same boundary dimensions as the GE...ES type and can be used internationally. A special PTFE liner reinforced with copper alloy meshes is used on the sliding surface. Therefore, creep deformation due to compressive loads is small, and wear resistance is superior. These bushings are used as maintenance-free bushings.

These bushings can be provided with synthetic resin seals which are effective in preventing dust penetration. They are indicated by the suffix "-2RS" at the end of the identification number.

Spherical Bushings with superior rust prevention properties, which can be used in a corrosive environment or in an environment where water splashes, are also available on request. Please consult IKO.

### Identification number

The identification number of Spherical Bushings consists of a model code, a size and any supplemental codes. Examples are shown below.

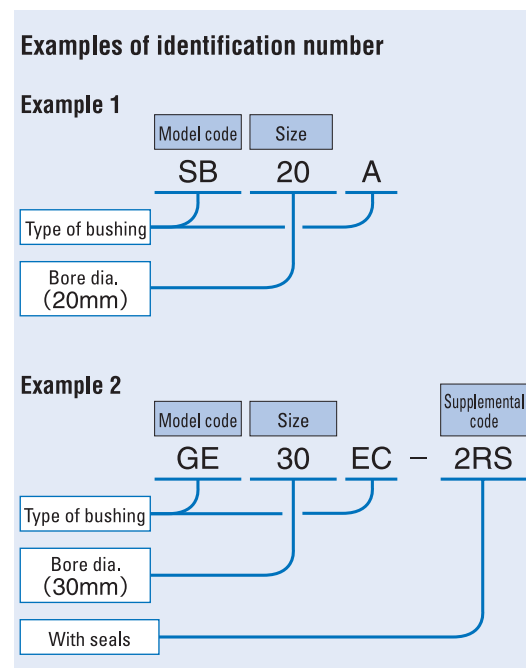

### Accuracy

The tolerances of Steel-on-steel Spherical Bushings of the metric series is shown in Table 2.

The tolerances of the GE type are applicable to bushings before splitting the outer ring and after surface treatment.

The tolerances of the SB and SB...A types are applicable to bushings before splitting the outer ring and before surface treatment.

The tolerances of the GE...EC type are applicable to bushings before splitting the outer ring.

The tolerances of the Spherical Bushings of the inch series are shown in Table 3. The tolerances of the bore diameter are applicable to bushings after surface treatment, while other tolerances are applicable to bushings before splitting the outer ring and before surface treatment.

Although minor dimensional changes may occur during surface treatment, they have negligible influence on the overall performance.

Table 2 Tolerances of inner and outer rings of metric series (JIS Class 0) unit:  $\mu\text{m}$

$d$ or $D$ <sup>(1)</sup> Nominal bore dia. or outside dia. mm	$\Delta_{dmp}$ Single plane mean bore dia. deviation		$\Delta_{Dmp}$ Single plane mean outside dia. deviation		$\Delta_{Bs}$ or $\Delta_{Cs}$ Deviation of a single inner ring width or outer ring width	
	High	Low	High	Low	High	Low
2.5	6	0 - 8	-	-	0	-120
6	18	0 - 8	0	- 8	0	-120
18	30	0 - 10	0	- 9	0	-120
30	50	0 - 12	0	- 11	0	-120
50	80	0 - 15	0	- 13	0	-150
80	120	0 - 20	0	- 15	0	-200
120	150	0 - 25	0	- 18	0	-250
150	180	0 - 25	0	- 25	0	-250
180	250	0 - 30	0	- 30	0	-300
250	315	0 - 35	0	- 35	0	-350
315	400	0 - 40	0	- 40	0	-400
400	500	0 - 45	0	- 45	0	-450

Note<sup>(1)</sup>  $d$  for  $\Delta_{dmp}$ ,  $\Delta_{Bs}$  and  $\Delta_{Cs}$  and  $D$  for  $\Delta_{Dmp}$ , respectively.

Table 3 Tolerances of inner and outer rings of inch series SBB unit:  $\mu\text{m}$

$d$ or $D$ <sup>(1)</sup> Nominal bore dia. or outside dia. mm	$\Delta_{dmp}$ Single plane mean bore dia. deviation		$\Delta_{Dmp}$ Single plane mean outside dia. deviation		$\Delta_{Bs}$ or $\Delta_{Cs}$ Deviation of a single inner ring width or outer ring width	
	High	Low	High	Low	High	Low
-	50.800	0 - 13	0	- 13	0	- 130
50.800	76.200	0 - 15	0	- 15	0	- 130
76.200	80.962	0 - 20	0	- 15	0	- 130
80.962	120.650	0 - 20	0	- 20	0	- 130
120.650	152.400	0 - 25	0	- 25	0	- 130
152.400	177.800	-	-	0 - 25	0	- 130
177.800	222.250	-	-	0 - 30	0	- 130

Note<sup>(1)</sup>  $d$  for  $\Delta_{dmp}$ ,  $\Delta_{Bs}$  and  $\Delta_{Cs}$  and  $D$  for  $\Delta_{Dmp}$ , respectively.

### Clearance

The radial internal clearances of Spherical Bushings are the values before splitting the outer ring, and are shown in Tables 4, 5 and 6. The radial internal clearances of the inch series are shown in the dimension table.

Clearances other than these can also be prepared on request. Please consult IKO.

Table 4 Radial internal clearance of SB and SB...A types (Steel-on-steel) unit:  $\mu\text{m}$

Nominal bore dia. $d$ mm	SB type		SB...A type	
	Min.	Max.	Min.	Max.
12			32	68
15	70	125	40	82
20				
22			50	100
25	75	140		
30				
35			60	120
40	85	150		
45				
50				
55				
60	90	160		
65				
70			72	142
75	95	170		
80				
85				
90				
95	100	185		
100			85	165
110				
115	110	200		
120				
130				
150	120	215	100	192

**Table 5 Radial internal clearance of GE type (Steel-on-steel)**  
unit:  $\mu\text{m}$

Nominal bore dia. mm		Radial internal clearance	
GE...E GE...ES	GE...G GE...GS	Min.	Max.
4	—	32	68
5	—		
6	—		
8	6		
10	8		
12	10		
15	12	40	82
17	15		
20	17		
25	20	50	100
30	25		
35	30		
40	35		
45	40		
50	45	60	120
60	50		
70	60		
80	70		
90	80	72	142
100	90		
110	100	85	165
120	110		
140	120		
160	140		
180	160	100	192
200	180		
220	200		
240	220		
260	240	110	214
280	260		
300	280		

Remark Also applicable to bushings with seals.

**Table 6 Radial internal clearance of GE...EC type (Maintenance-free)**  
unit:  $\mu\text{m}$

Nominal bore dia. mm	Radial internal clearance	
	Min.	Max.
15	0	40
17		
20		
25	0	50
30		
35		
40		
45	0	60
50		
60		
70		
70	0	72

Remark Also applicable to bushings with seals.

**Fit**

The recommended fits for Spherical Bushings are shown in Tables 7 and 8.

**Table 7 Recommended fits for Steel-on-steel Spherical Bushings**

Condition	Tolerance class	
	Shaft	Housing bore
Normal operation	h6, j6	H7, J7
With directionally indeterminate load	m6, n6	M7, N7

Remark N7 tolerance is recommended for light metal housings.

**Table 8 Recommended fits for Maintenance-free Spherical Bushings**

Tolerance class of shaft	Tolerance class of housing bore
h6, j6	H7, J7, K7

Remark K7 tolerance is recommended for light metal housings.

**Selection of Spherical Bushings**

Selection between the steel-on-steel type and the maintenance-free type is made considering the operating conditions such as load, lubrication, temperature, and sliding velocity.

**Load capacity**

**1 Dynamic load capacity**

The dynamic load capacity  $C_d$  is the maximum allowable load that can be applied on a spherical bushing under oscillating motion. It is obtained on the basis of the contact pressure on the spherical surfaces. The dynamic load capacity is also used for calculating the life of spherical bushings.

The recommended value of bushing load is obtained by multiplying the dynamic load capacity  $C_d$  by a numerical factor, which differs depending on the bushing type and the load condition. A guideline for selection is shown in Table 9.

**Table 9 Guide for determination of load**

Type of bushing	Load direction	
	Constant	Alternate
Steel-on-steel	$\leq 0.3C_d$	$\leq 0.6C_d$
Maintenance-free	$\leq C_d$	$\leq 0.5C_d$

When the magnitude of load exceeds the value given in Table 9, please consult IKO.

The dynamic load capacity  $C_{dt}$  considering the influence of bushing temperature can be obtained from the following equation using the temperature factor.

$$C_{dt} = f_t C_d \quad \text{.....(1)}$$

where,  $C_{dt}$ : Dynamic load capacity considering temperature increase N

$f_t$ : Temperature factor (Refer to Table 10.)

$C_d$ : Dynamic load capacity N (Refer to the dimension tables.)

**Table 10 Temperature factor  $f_t$**

Type of bushing		Temperature $^{\circ}\text{C}$					
		-30 +80	+80 +90	+90 +100	+100 +120	+120 +150	+150 +180
Steel-on-steel	Without seals	1	1	1	1	1	0.7
	With seals	1	—	—	—	—	—
Maintenance-free	Without seals	1	1	0.9	0.75	0.55	—
	With seals	1	—	—	—	—	—

**2 Static load capacity**

The static load capacity  $C_s$  is the maximum static load that can be applied on the spherical bushing without breaking inner and outer rings or causing any permanent deformation severe enough to render the bushing unusable.

It must be noted that if the magnitude of the applied load becomes comparable to the static load capacity of bushing, the stresses in the shaft or housing may also reach to their limits. This possibility must be taken into consideration in the design.

**Equivalent radial load**

Spherical Bushings can take radial and axial loads at the same time. When the magnitude and direction of loads are constant, the equivalent radial load can be obtained from the following equation.

$$P = F_r + YF_a \quad \text{.....(2)}$$

where,  $P$ : Equivalent radial load N

$F_r$ : Radial load N

$F_a$ : Axial load N

$Y$ : Axial load factor (Refer to Table 11.)

**Table 11 Axial load factor  $Y$**

Type of bushing	$F_a/F_r$					
	0.1	0.2	0.3	0.4	0.5	> 0.5
Steel-on-steel	1	2	3	4	5	Unusable
Maintenance-free	1	2	3	Unusable		

**Life**

The life of Spherical Bushings is defined as the total number of oscillating motions before the bushings cannot be operated normally because of wear, increase in internal clearance, increase in sliding torque, rise of operating temperature, etc.

As the actual life is affected by many factors such as the material of the sliding surface, the magnitude and direction of load, lubrication, sliding velocity, etc., the calculated life can be used as a practical measure of expected service life.

**1 Life of Steel-on-steel spherical bushings**

[1] Confirmation of  $pV$  value

Before attempting to calculate the life, make sure that the operating conditions are within the permissible range by referring to the  $pV$  diagram in Fig.1.

When the operating conditions are out of the permissible range, please consult IKO.

The contact pressure  $p$  and the sliding velocity  $V$  are obtained from the following equations.

$$p = \frac{100P}{C_{dt}} \quad \text{.....(3)}$$

$$V = 5.82 \times 10^{-4} d_k \beta f \quad \text{.....(4)}$$

where,  $p$ : Contact pressure N/mm<sup>2</sup>

$P$ : Equivalent radial load N (Refer to equation (2).)

$C_{dt}$ : Dynamic load capacity considering temperature increase N (Refer to equation (1).)

$V$ : Sliding velocity mm/s

$d_k$ : Sphere diameter mm

(Refer to the dimension tables.)

$2\beta$ : Oscillating angle degrees (Refer to Fig.2.)

when  $\beta < 5^{\circ}$ ,  $\beta = 5$

when rotating,  $\beta = 90$

$f$ : Number of oscillations per minute min<sup>-1</sup>

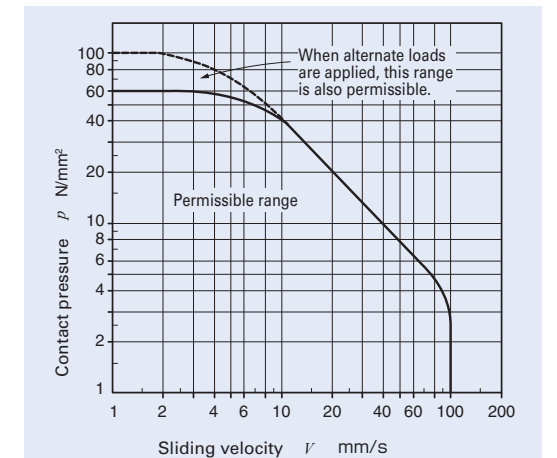

**Fig.1  $pV$  diagram of Steel-on-steel spherical bushings**

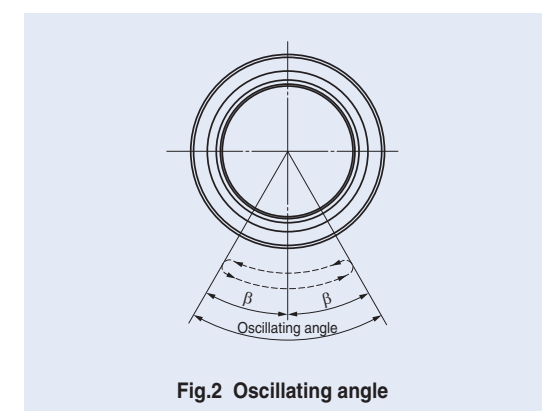

**Fig.2 Oscillating angle**

[2] Life calculation

The life of steel-on-steel spherical bushings can be calculated from the following equations.

$$G = \frac{3.18b_1b_2b_3}{\sqrt{d_k} \beta} \left(\frac{C_{dt}}{P}\right)^2 \times 10^5 \dots\dots\dots (5)$$

$$L_h = \frac{G}{60f} \dots\dots\dots (6)$$

- where,  $G$  : Life (Total number of oscillations)
- $b_1$  : Load directional factor (Refer to Table 12.)
- $b_2$  : Lubrication factor (Refer to Table 13.)
- $b_3$  : Sliding velocity factor (Refer to Fig.3.)
- $C_{dt}$  : Dynamic load capacity considering temperature increase N  
(Refer to equation (1).)
- $P$  : Equivalent radial load N  
(Refer to equation (2).)
- $L_h$  : Life in hours h
- $f$  : Number of oscillations per minute  $\text{min}^{-1}$

Table 12 Load directional factor  $b_1$  (Steel-on-steel)

Load direction	Constant	Alternate
Load directional factor $b_1$	1	5

Table 13 Lubrication factor  $b_2$

Periodical lubrication	None	Regular
Lubrication factor $b_2$	1	15

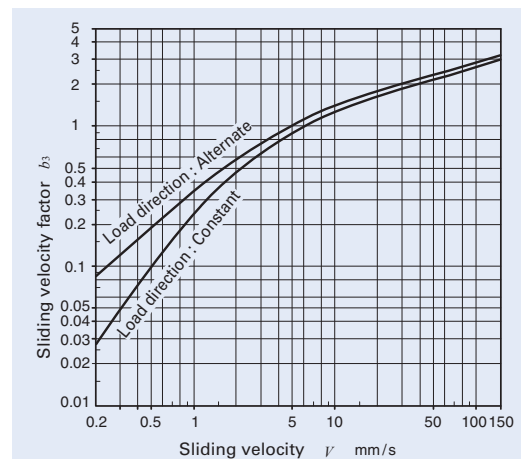

Fig.3 Sliding velocity factor

② Life of Maintenance-free spherical bushings

[1] Confirmation of  $pV$  value

Before attempting to calculate the life, make sure that the operating conditions are within the permissible range by referring to the  $pV$  diagram in Fig.4.

When the operating conditions are out of the permissible range, please consult IKO.

The contact pressure  $p$  and the sliding velocity  $V$  are obtained from equations (3) and (4) shown on page K6.

[2] Life calculation

The life of maintenance-free spherical bushings is obtained from the total sliding distance  $S$  which is given in Fig.5 for the contact pressure  $p$  obtained from equation (3).

The total number of oscillations and life in hours can be obtained from the following equations.

$$G = 16.67 \times b_1 \frac{Sf}{V} \dots\dots\dots (7)$$

$$L_h = \frac{G}{60f} \dots\dots\dots (8)$$

- where,  $G$  : Life (Total number of oscillations)
- $b_1$  : Load directional factor (Refer to Table 14.)
- $S$  : Total sliding distance m (Refer to Fig.5.)
- $f$  : Number of oscillations per minute  $\text{min}^{-1}$
- $V$  : Sliding velocity  $\text{mm/s}$
- $L_h$  : Life in hours h

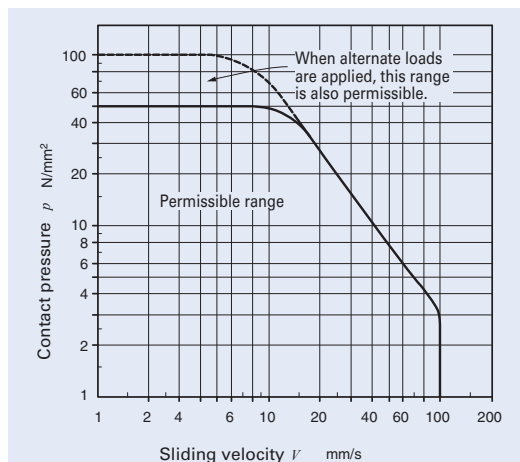

Fig.4  $pV$  diagram of Maintenance-free spherical bushings

Table 14 Load directional factor  $b_1$  (Maintenance-free)

Load direction	Constant	Alternate
Load directional factor $b_1$	1	0.2 <sup>(1)</sup>

Note<sup>(1)</sup> This value is applicable when the load changes comparatively slowly. When the load changes rapidly, please consult IKO, as the factor decreases sharply.

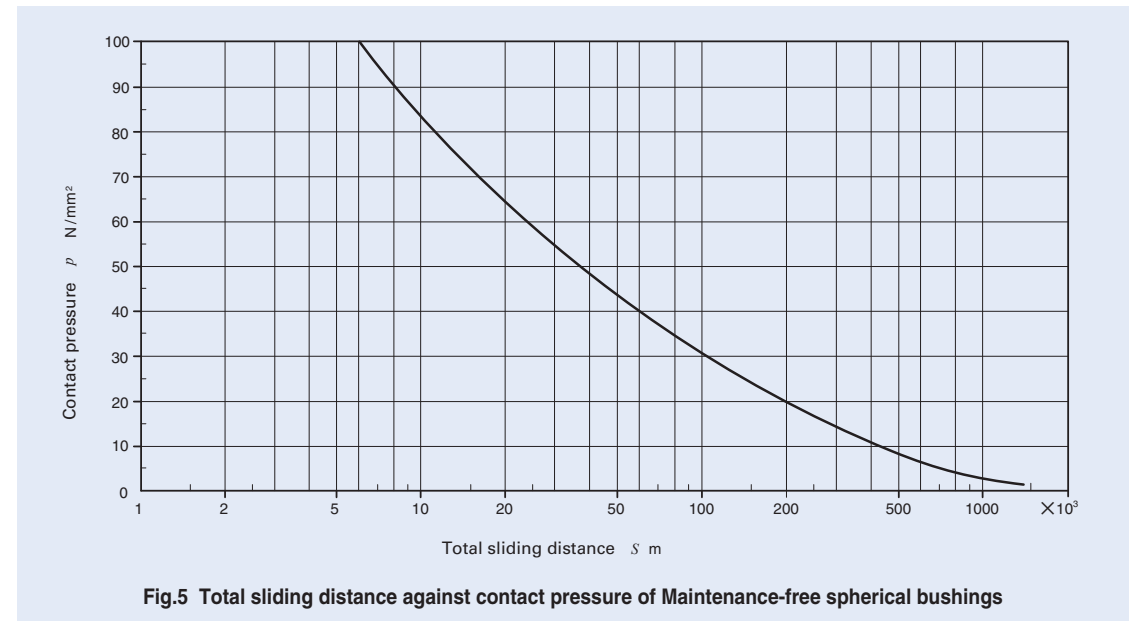

Fig.5 Total sliding distance against contact pressure of Maintenance-free spherical bushings

■ Lubrication

Steel-on-steel Spherical Bushings require periodic grease lubrication as a general rule. During initial operation, it is recommended to shorten the lubrication interval. Lithium soap based grease (NLGI consistency No.2) containing molybdenum disulfide (MoS2) is widely used as the lubrication grease. For Maintenance-free Spherical Bushings, lubrication is not required. However, supplying lithium soap based grease before operation can extend the life of the Spherical Bushing. Also, to protect the bearing from foreign substances and corrosion, it is effective to fill the area around the bearing with grease.

■ Oil Hole

The number of oil holes on inner and outer rings is shown in Table 15.

Table 15 Number of oil holes on inner and outer rings

Bushing type			Number of oil holes on inner and outer rings
Steel-on-steel Spherical Bushings	Metric series	GE...E	0
		GE...G	
	Inch series	SBB	2
		SB, SB...A, GE...ES, GE...GS	
Maintenance-free Spherical Bushings	Metric series	GE...EC	0

Remark Types with oil holes are also provided with oil grooves on inner and outer rings.



## Operating Temperature Range

The operating temperature range for Spherical Bushings with seals is -30°C~+80°C.

The maximum allowable temperature for Spherical Bushings without seals is +180 °C for the steel-on-steel type and +150 °C for the maintenance-free type.

## Precautions for Use

### Design of shaft

When the load is large, sliding may occur between the shaft and the inner ring bore of bushing. For such cases, it is necessary to prepare the shaft with a hardness of 58HRC or greater and surface roughness of 0.8 μmR<sub>a</sub> or less.

Furthermore, attention must be paid to the strength of shaft because the shear and/or bending stresses in the shaft may surpass the allowable values even when the load is below the static load capacity of Spherical Bushings.

### Design of housing

The housing should have sufficient rigidity to avoid harmful deformation under load.

When the housing shown in Fig.6 is used, it should be designed with sufficient strength as follows.

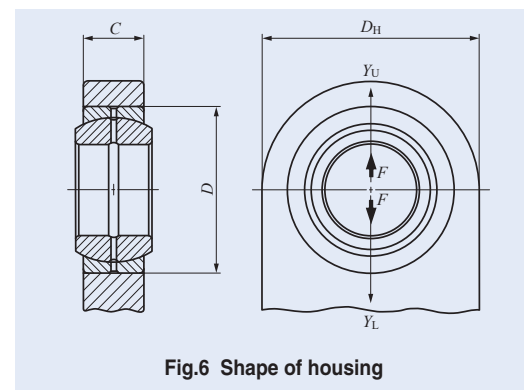

Fig.6 Shape of housing

#### ① When the load acts in the Y<sub>L</sub> direction;

Select the housing material considering the compressive stress obtained from the following equation.

$$\sigma_1 = \frac{F}{CD} \dots\dots\dots(9)$$

where, σ<sub>1</sub> : Maximum compressive stress occurring in the housing bore N/mm<sup>2</sup>

F : Applied load N

C : Width of outer ring and housing mm

D : Outside diameter of outer ring mm

#### ② When the load acts in the Yu direction ;

Select the housing material considering the tensile stress obtained from the following equation.

$$\sigma_2 = \frac{F}{C(D_H - D)} k \dots\dots\dots(10)$$

where, σ<sub>2</sub> : Maximum tensile stress occurring in the housing bore N/mm<sup>2</sup>

F : Applied load N

C : Width of outer ring and housing mm

D<sub>H</sub> : Outside diameter of housing mm

D : Outside diameter of outer ring mm

k : Stress concentration factor (Refer to Fig.7.)

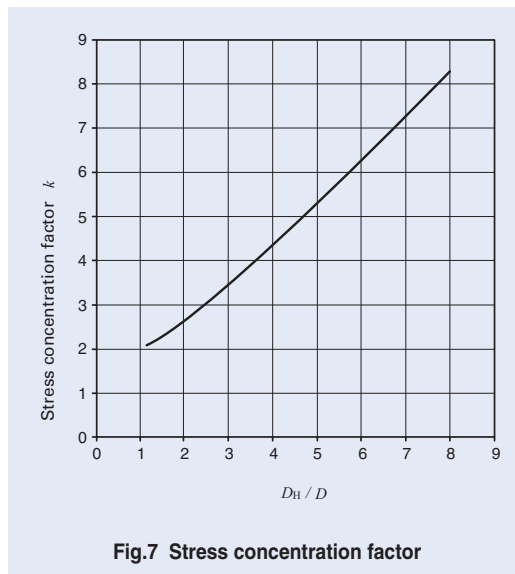

Fig.7 Stress concentration factor

## Mounting

① When mounting Spherical Bushings, pay attention to the location of the split plane of the outer ring. Set the split plane at right angles to the direction of load to avoid the application of load to the split plane as shown in Fig. 8.

② The shoulder dimensions of shaft and housing are shown in the dimension tables.

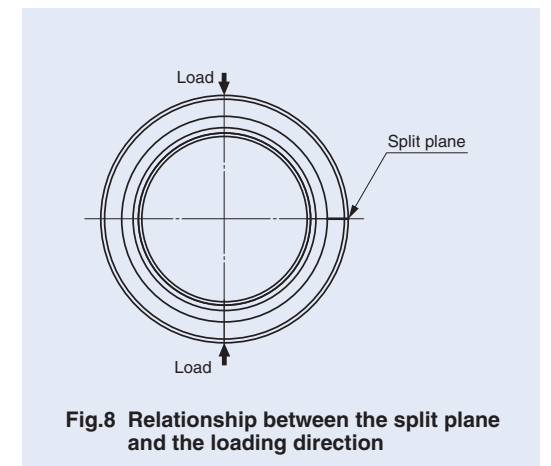

Fig.8 Relationship between the split plane and the loading direction

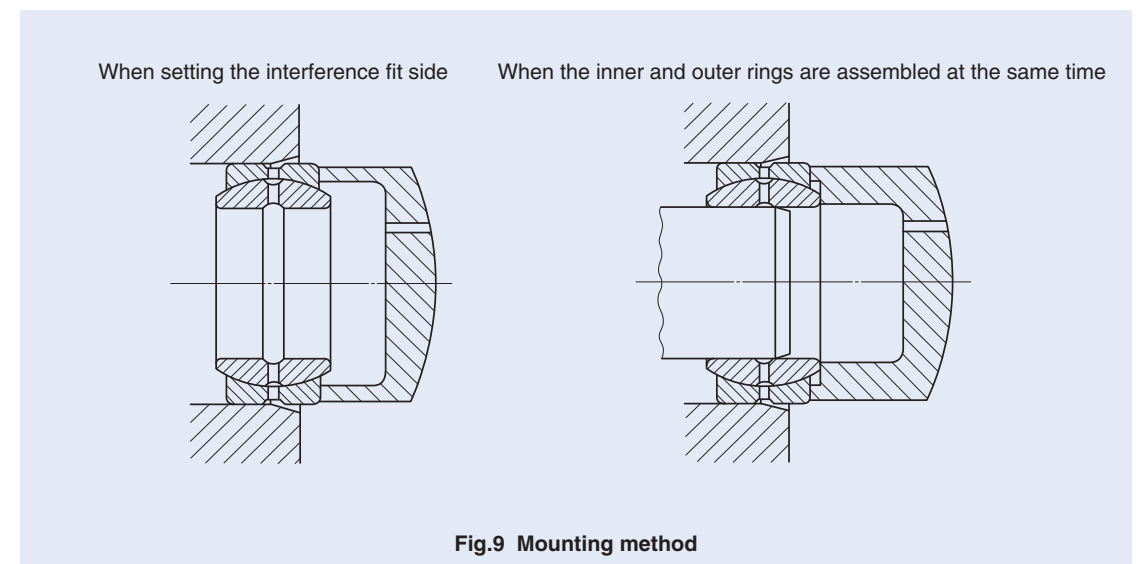

Fig.9 Mounting method

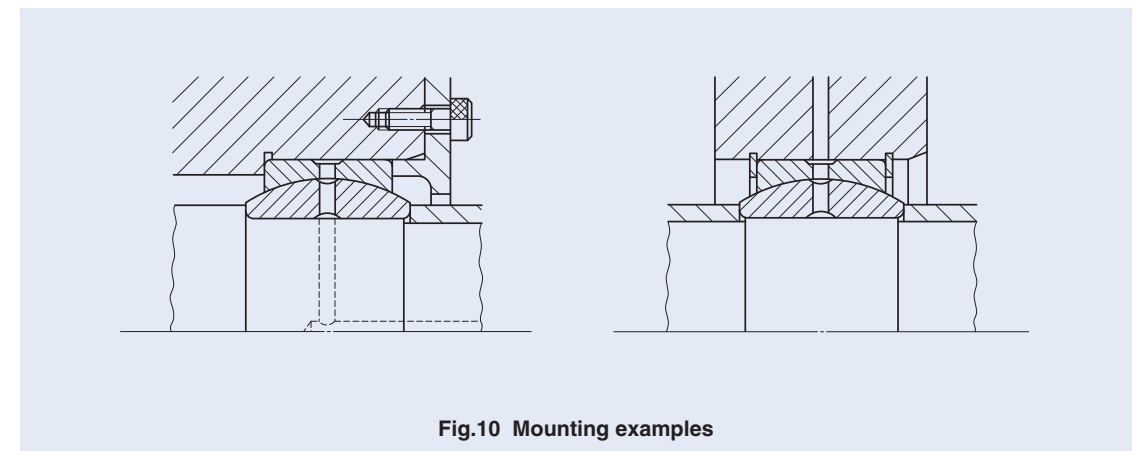

Fig.10 Mounting examples

**SPHERICAL BUSHINGS**

Steel-on-steel Spherical Bushings



Shaft dia. 12 – 100mm

Shaft dia. mm	Identification number		Mass (Ref.) kg	Boundary dimensions mm						Permissible tilting angle degree $\alpha$
				$d$	$D$	$B$	$C$	$d_k$	$r_{s \text{ min}}^{(1)}$	
12	SB 12A	SB 122211	0.019	12	22	11	9	18	0.3	7
15	SB 15A	SB 152613	0.028	15	26	13	11	22	0.3	6
20	SB 20A	SB 203216	0.053	20	32	16	14	28	0.3	4
22	SB 22A	SB 223719	0.085	22	37	19	16	32	0.3	6
25	SB 25A	SB 254221	0.116	25	42	21	18	36	0.3	5
30	SB 30A	SB 305027	0.225	30	50	27	23	45	0.6	6
35	SB 35A	SB 355530	0.300	35	55	30	26	50	0.6	5
40	SB 40A	SB 406233	0.375	40	62	33	28	55	0.6	6
45	SB 45A	SB 457236	0.600	45	72	36	31	62	0.6	5
50	SB 50A	SB 508042	0.870	50	80	42	36	72	0.6	5
55	SB 55A	SB 559047	1.26	55	90	47	40	80	0.6	5
60	SB 60A	SB 6010053	1.70	60	100	53	45	90	0.6	6
65	SB 65A	SB 6510555	2.05	65	105	55	47	94	0.6	5
70	SB 70A	SB 7011058	2.22	70	110	58	50	100	0.6	5
75	SB 75A	SB 7512064	3.02	75	120	64	55	110	0.6	5
80	SB 80A	SB 8013070	3.98	80	130	70	60	120	0.6	5
85	SB 85A	SB 8513574	4.29	85	135	74	63	125	0.6	6
90	SB 90A	SB 9014076	4.71	90	140	76	65	130	0.6	5
95	SB 95A	SB 9515082	6.05	95	150	82	70	140	0.6	5
100	SB 100A	SB 10016088	7.42	100	160	88	75	150	1	5

Notes<sup>(1)</sup> Minimum allowable value of chamfer dimensions  $r_1$  and  $r_2$   
<sup>(2)</sup> When Spherical Bushings are used with full tilting angle, the shaft shoulder dimension must be less than the maximum value of  $d_a$ .  
 Remarks1. The inner ring and the outer ring have an oil groove and two oil holes, respectively.  
 2. No grease is prepacked. Perform proper lubrication.

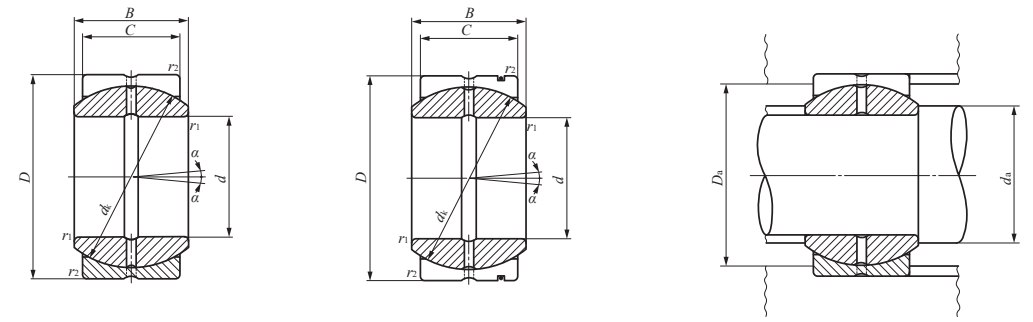

Mounting dimensions mm				Dynamic load capacity $C_d$ N	Static load capacity $C_s$ N
$d_a$		$D_a$			
Min.	Max. <sup>(2)</sup>	Max.	Min.		
14	14	19.5	17	15 900	95 300
17.5	17.5	23.5	21	23 700	142 000
22.5	23	29.5	26	38 400	231 000
24.5	25.5	34.5	30	50 200	301 000
27.5	29	39.5	34	63 500	381 000
34.5	36	45.5	42	101 000	609 000
39.5	40	50.5	46.5	127 000	765 000
44	44	57.5	51.5	151 000	906 000
49.5	50.5	67.5	58	188 000	1 130 000
54.5	58.5	75.5	67	254 000	1 530 000
59.5	64.5	85.5	74.5	314 000	1 880 000
64.5	72.5	95.5	83.5	397 000	2 380 000
69.5	76	100.5	87	433 000	2 600 000
74.5	81.5	105.5	93	490 000	2 940 000
79.5	89.5	115.5	102	593 000	3 560 000
84.5	97.5	125.5	112	706 000	4 240 000
89.5	100.5	130.5	116	772 000	4 630 000
94.5	105.5	135.5	121	829 000	4 970 000
99.5	113.5	145.5	130	961 000	5 770 000
105.5	121.5	154.5	139	1 100 000	6 620 000

**SPHERICAL BUSHINGS**

Steel-on-steel Spherical Bushings



Shaft dia. 110 – 150mm

Shaft dia. mm	Identification number		Mass (Ref.) kg	Boundary dimensions mm						Permissible tilting angle degree $\alpha$
				$d$	$D$	$B$	$C$	$d_k$	$r_{s \text{ min}}^{(1)}$	
110	<b>SB 110A</b>	<b>SB 11017093</b>	8.55	110	170	93	80	160	1	5
115	<b>SB 115A</b>	<b>SB 11518098</b>	10.3	115	180	98	85	165	1	5
120	<b>SB 120A</b>	<b>SB 120190105</b>	12.4	120	190	105	90	175	1	5
130	<b>SB 130A</b>	<b>SB 130200110</b>	13.8	130	200	110	95	185	1	5
150	<b>SB 150A</b>	<b>SB 150220120</b>	17.0	150	220	120	105	205	1	5

Notes<sup>(1)</sup> Minimum allowable value of chamfer dimensions  $r_1$  and  $r_2$   
<sup>(2)</sup> When Spherical Bushings are used with full tilting angle, the shaft shoulder dimension must be less than the maximum value of  $d_a$ .  
 Remarks1. The inner ring and the outer ring have an oil groove and two oil holes, respectively.  
 2. No grease is prepacked. Perform proper lubrication.

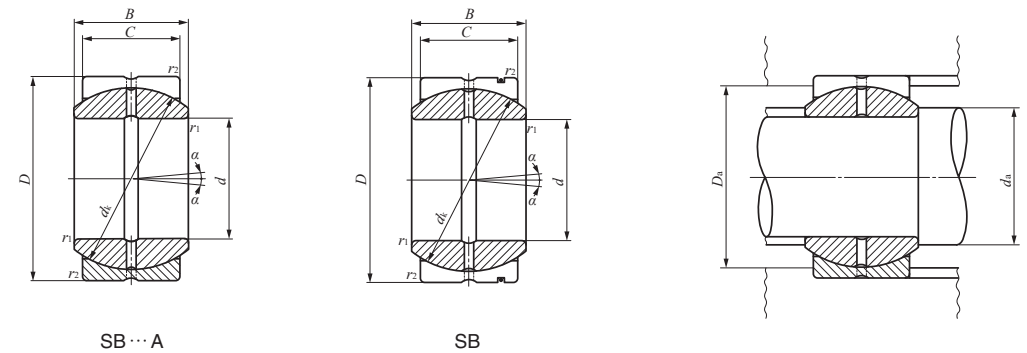

Mounting dimensions mm				Dynamic load capacity $C_d$ N	Static load capacity $C_s$ N
Min.	$d_a$ Max. <sup>(2)</sup>	Max.	$D_a$ Min.		
115.5	130	164.5	149	1 260 000	7 530 000
120.5	132.5	174.5	152	1 380 000	8 250 000
125.5	140	184.5	162	1 540 000	9 270 000
135.5	148.5	194.5	171	1 720 000	10 300 000
155.5	166	214.5	189	2 110 000	12 700 000

**SPHERICAL BUSHINGS**

Steel-on-steel Spherical Bushings

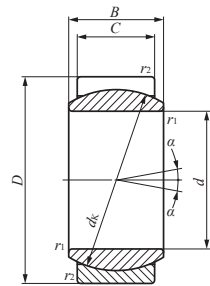

GE...E

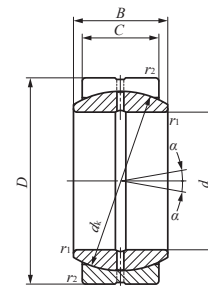

GE...ES

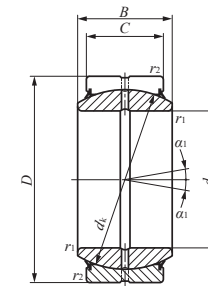

GE...ES-2RS

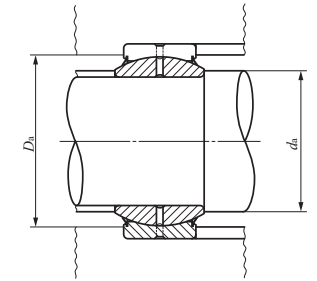

Shaft dia. 4 – 100mm

Shaft dia. mm	Identification number		Mass (Ref.) kg	Boundary dimensions mm							Permissible tilting angle degree	
	Without seals	With seals		d	D	B	C	dk	r <sub>1s</sub> <sup>(1)</sup> min	r <sub>2s</sub> <sup>(1)</sup> min	α	α <sub>1</sub>
4	GE 4E	—	0.003	4	12	5	3	8	0.3	0.3	16	—
5	GE 5E	—	0.004	5	14	6	4	10	0.3	0.3	13	—
6	GE 6E	—	0.004	6	14	6	4	10	0.3	0.3	13	—
8	GE 8E	—	0.008	8	16	8	5	13	0.3	0.3	15	—
10	GE 10E	—	0.012	10	19	9	6	16	0.3	0.3	12	—
12	GE 12E	—	0.017	12	22	10	7	18	0.3	0.3	11	—
15	GE 15ES	GE 15ES-2RS	0.032	15	26	12	9	22	0.3	0.3	8	5
17	GE 17ES	GE 17ES-2RS	0.049	17	30	14	10	25	0.3	0.3	10	7
20	GE 20ES	GE 20ES-2RS	0.065	20	35	16	12	29	0.3	0.3	9	6
25	GE 25ES	GE 25ES-2RS	0.115	25	42	20	16	35.5	0.6	0.6	7	4
30	GE 30ES	GE 30ES-2RS	0.160	30	47	22	18	40.7	0.6	0.6	6	4
35	GE 35ES	GE 35ES-2RS	0.258	35	55	25	20	47	0.6	1	6	4
40	GE 40ES	GE 40ES-2RS	0.315	40	62	28	22	53	0.6	1	7	4
45	GE 45ES	GE 45ES-2RS	0.413	45	68	32	25	60	0.6	1	7	4
50	GE 50ES	GE 50ES-2RS	0.560	50	75	35	28	66	0.6	1	6	4
60	GE 60ES	GE 60ES-2RS	1.10	60	90	44	36	80	1	1	6	3
70	GE 70ES	GE 70ES-2RS	1.54	70	105	49	40	92	1	1	6	4
80	GE 80ES	GE 80ES-2RS	2.29	80	120	55	45	105	1	1	6	4
90	GE 90ES	GE 90ES-2RS	2.82	90	130	60	50	115	1	1	5	3
100	GE 100ES	GE 100ES-2RS	4.43	100	150	70	55	130	1	1	7	5

Notes<sup>(1)</sup> Minimum allowable value of chamfer dimensions  $r_1$  and  $r_2$   
<sup>(2)</sup> When Spherical Bushings are used with full tilting angle, the shaft shoulder dimension must be less than the maximum value of  $d_a$ .  
 Remarks1. GE...E has no oil hole. Others are provided with an oil groove and two oil holes on the inner ring and outer ring, respectively.  
 2. No grease is prepacked. Perform proper lubrication.

Mounting dimensions mm				Dynamic load capacity $C_d$ N	Static load capacity $C_s$ N
$d_a$		$D_a$			
Min.	Max. <sup>(2)</sup>	Max.	Min.		
6	6	9.5	8	2 350	14 100
7.5	8	11.5	10	3 920	23 500
8	8	11.5	10	3 920	23 500
10	10	13.5	13	6 370	38 200
12.5	13	16.5	15.5	9 410	56 500
14.5	15	19.5	17	12 400	74 100
17.5	18	23.5	22.5	19 400	117 000
19.5	20.5	27.5	26	24 500	147 000
22.5	24	32.5	30.5	34 100	205 000
29	29	37.5	37	55 700	334 000
34	34	42.5	41.5	71 800	431 000
39.5	39.5	49.5	48	92 200	553 000
44.5	45	56.5	54.5	114 000	686 000
49.5	50.5	62.5	60	147 000	883 000
54.5	56	69.5	66	181 000	1 090 000
65.5	66.5	84.5	79	282 000	1 690 000
75.5	77.5	99.5	91	361 000	2 170 000
85.5	89	114.5	103	463 000	2 780 000
95.5	98	124.5	112	564 000	3 380 000
105.5	109.5	144.5	127	701 000	4 210 000



**SPHERICAL BUSHINGS**

Steel-on-steel Spherical Bushings



Shaft dia. 110 – 300mm

Shaft dia. mm	Identification number		Mass (Ref.) kg	Boundary dimensions mm							Permissible tilting angle degree	
	Without seals	With seals		$d$	$D$	$B$	$C$	$d_k$	$r_{1s \min}^{(1)}$	$r_{2s \min}^{(1)}$	$\alpha$	$\alpha_1$
110	GE 110ES	GE 110ES-2RS	4.94	110	160	70	55	140	1	1	6	4
120	GE 120ES	GE 120ES-2RS	8.12	120	180	85	70	160	1	1	6	4
140	GE 140ES	GE 140ES-2RS	11.4	140	210	90	70	180	1	1	7	5
160	GE 160ES	GE 160ES-2RS	14.4	160	230	105	80	200	1	1	8	6
180	GE 180ES	GE 180ES-2RS	18.9	180	260	105	80	225	1.1	1.1	6	5
200	GE 200ES	GE 200ES-2RS	28.1	200	290	130	100	250	1.1	1.1	7	6
220	GE 220ES	GE 220ES-2RS	36.1	220	320	135	100	275	1.1	1.1	8	6
240	GE 240ES	GE 240ES-2RS	40.4	240	340	140	100	300	1.1	1.1	8	6
260	GE 260ES	GE 260ES-2RS	52.0	260	370	150	110	325	1.1	1.1	7	6
280	GE 280ES	GE 280ES-2RS	66.0	280	400	155	120	350	1.1	1.1	6	5
300	GE 300ES	GE 300ES-2RS	76.0	300	430	165	120	375	1.1	1.1	7	6

Notes<sup>(1)</sup> Minimum allowable value of chamfer dimensions  $r_1$  and  $r_2$   
<sup>(2)</sup> When Spherical Bushings are used with full tilting angle, the shaft shoulder dimension must be less than the maximum value of  $d_a$ .  
 Remarks1. The inner ring and the outer ring have an oil groove and two oil holes, respectively.  
 2. No grease is prepacked. Perform proper lubrication.

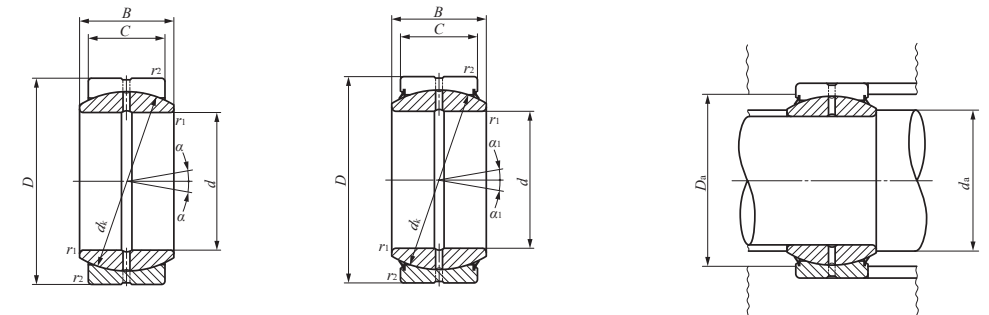

GE...ES

GE...ES-2RS

Mounting dimensions mm				Dynamic load capacity $C_d$ N	Static load capacity $C_s$ N
$d_a$		$D_a$			
Min.	Max. <sup>(2)</sup>	Max.	Min.		
115.5	121	154.5	138	755 000	4 530 000
125.5	135.5	174.5	154	1 100 000	6 590 000
145.5	155.5	204.5	176	1 240 000	7 410 000
165.5	170	224.5	195	1 570 000	9 410 000
187	199	253	221	1 770 000	10 600 000
207	213.5	283	244	2 450 000	14 700 000
227	239.5	313	269	2 700 000	16 200 000
247	265	333	296	2 940 000	17 700 000
267	288	363	320	3 510 000	21 000 000
287	313.5	393	345	4 120 000	24 700 000
307	336.5	423	371	4 410 000	26 500 000

**SPHERICAL BUSHINGS**

Steel-on-steel Spherical Bushings

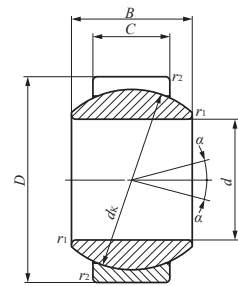

GE...G

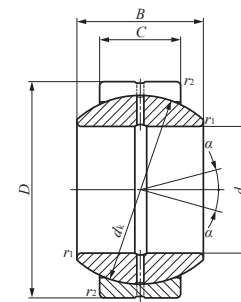

GE...GS

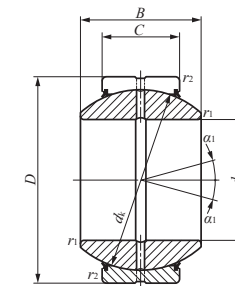

GE...GS-2RS

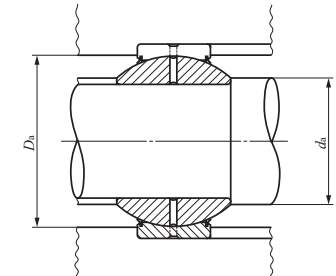

Shaft dia. 6 – 120mm

Shaft dia. mm	Identification number		Mass (Ref.) kg	Boundary dimensions mm							Permissible tilting angle degree	
	Without seals	With seals		d	D	B	C	dk	r <sub>1s min</sub> <sup>(1)</sup>	r <sub>2s min</sub> <sup>(1)</sup>	α	α <sub>1</sub>
6	GE 6G	—	0.010	6	16	9	5	13	0.3	0.3	21	—
8	GE 8G	—	0.015	8	19	11	6	16	0.3	0.3	21	—
10	GE 10G	—	0.022	10	22	12	7	18	0.3	0.3	18	—
12	GE 12G	—	0.041	12	26	15	9	22	0.3	0.3	18	—
15	GE 15GS	GE 15GS-2RS	0.059	15	30	16	10	25	0.3	0.3	16	13
17	GE 17GS	GE 17GS-2RS	0.083	17	35	20	12	29	0.3	0.3	19	16
20	GE 20GS	GE 20GS-2RS	0.155	20	42	25	16	35.5	0.3	0.6	17	16
25	GE 25GS	GE 25GS-2RS	0.215	25	47	28	18	40.7	0.6	0.6	17	15
30	GE 30GS	GE 30GS-2RS	0.330	30	55	32	20	47	0.6	1	17	16
35	GE 35GS	GE 35GS-2RS	0.400	35	62	35	22	53	0.6	1	16	15
40	GE 40GS	GE 40GS-2RS	0.515	40	68	40	25	60	0.6	1	17	14
45	GE 45GS	GE 45GS-2RS	0.660	45	75	43	28	66	0.6	1	15	13
50	GE 50GS	GE 50GS-2RS	1.50	50	90	56	36	80	0.6	1	17	16
60	GE 60GS	GE 60GS-2RS	2.05	60	105	63	40	92	1	1	17	15
70	GE 70GS	GE 70GS-2RS	3.00	70	120	70	45	105	1	1	16	14
80	GE 80GS	GE 80GS-2RS	3.60	80	130	75	50	115	1	1	14	13
90	GE 90GS	GE 90GS-2RS	5.41	90	150	85	55	130	1	1	15	14
100	GE 100GS	GE 100GS-2RS	6.15	100	160	85	55	140	1	1	14	12
110	GE 110GS	GE 110GS-2RS	9.70	110	180	100	70	160	1	1	12	11
120	GE 120GS	GE 120GS-2RS	15.5	120	210	115	70	180	1	1	16	15

Notes<sup>(1)</sup> Minimum allowable value of chamfer dimensions  $r_1$  and  $r_2$   
<sup>(2)</sup> When Spherical Bushings are used with full tilting angle, the shaft shoulder dimension must be less than the maximum value of  $d_a$ .  
 Remarks1. GE...G has no oil hole. Others are provided with an oil groove and two oil holes on the inner ring and outer ring, respectively.  
 2. No grease is prepacked. Perform proper lubrication.

Mounting dimensions mm				Dynamic load capacity $C_d$ N	Static load capacity $C_s$ N
Min.	Max. <sup>(2)</sup>	Max.	Min.		
8.5	9	13.5	13	6 370	38 200
10.5	11.5	16.5	15.5	9 410	56 500
12.5	13	19.5	17	12 400	74 100
14.5	16	23.5	21	19 400	117 000
17.5	19	27.5	26	24 500	147 000
19.5	21	32.5	30.5	34 100	205 000
22.5	25	37.5	37	55 700	334 000
29.5	29.5	42.5	41.5	71 800	431 000
34	34	49.5	48	92 200	553 000
39.5	39.5	56.5	54.5	114 000	686 000
44.5	44.5	62.5	60	147 000	883 000
49.5	50	69.5	66	181 000	1 090 000
54.5	57	84.5	79	282 000	1 690 000
65.5	67	99.5	91	361 000	2 170 000
75.5	78	114.5	103	463 000	2 780 000
85.5	87	124.5	112	564 000	3 380 000
95.5	98	144.5	127	701 000	4 210 000
105.5	111	154.5	138	755 000	4 530 000
115.5	124.5	174.5	154	1 100 000	6 590 000
125.5	138.5	204.5	176	1 240 000	7 410 000

**SPHERICAL BUSHINGS**

Steel-on-steel Spherical Bushings



Shaft dia. 140 – 280mm

Shaft dia. mm	Identification number		Mass (Ref.) kg	Boundary dimensions mm							Permissible tilting angle degree	
	Without seals	With seals		$d$	$D$	$B$	$C$	$d_k$	$r_{1s \min}^{(1)}$	$r_{2s \min}^{(1)}$	$\alpha$	$\alpha_1$
140	GE 140GS	GE 140GS-2RS	19.2	140	230	130	80	200	1	1	16	15
160	GE 160GS	GE 160GS-2RS	25.4	160	260	135	80	225	1	1.1	16	14
180	GE 180GS	GE 180GS-2RS	34.7	180	290	155	100	250	1.1	1.1	14	13
200	GE 200GS	GE 200GS-2RS	43.8	200	320	165	100	275	1.1	1.1	15	14
220	GE 220GS	GE 220GS-2RS	51.3	220	340	175	100	300	1.1	1.1	16	14
240	GE 240GS	GE 240GS-2RS	66.1	240	370	190	110	325	1.1	1.1	15	14
260	GE 260GS	GE 260GS-2RS	81.8	260	400	205	120	350	1.1	1.1	15	14
280	GE 280GS	GE 280GS-2RS	97.4	280	430	210	120	375	1.1	1.1	15	14

Notes<sup>(1)</sup> Minimum allowable value of chamfer dimensions  $r_1$  and  $r_2$   
<sup>(2)</sup> When Spherical Bushings are used with full tilting angle, the shaft shoulder dimension must be less than the maximum value of  $d_a$ .  
 Remarks1. The inner ring and the outer ring have an oil groove and two oil holes, respectively.  
 2. No grease is prepacked. Perform proper lubrication.

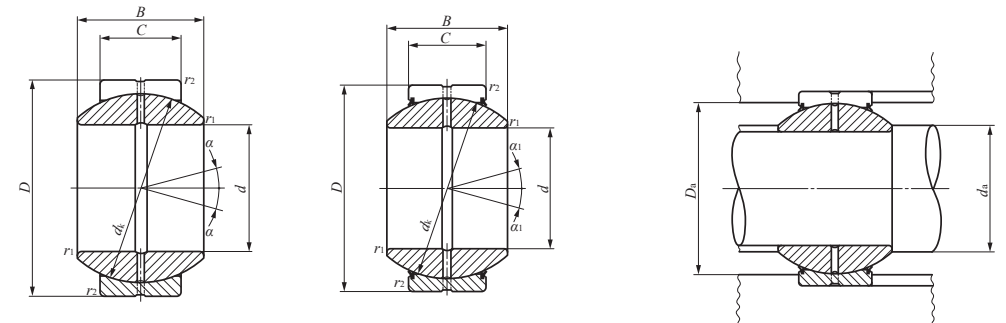

GE...GS

GE...GS-2RS

Mounting dimensions mm				Dynamic load capacity	Static load capacity
$d_a$		$D_a$		$C_d$	$C_s$
Min.	Max. <sup>(2)</sup>	Max.	Min.	N	N
145.5	152	224.5	195	1 570 000	9 410 000
165.5	180	253	221	1 770 000	10 600 000
187	196	283	244	2 450 000	14 700 000
207	220	313	269	2 700 000	16 200 000
227	243.5	333	296	2 940 000	17 700 000
247	263.5	363	320	3 510 000	21 000 000
267	283.5	393	345	4 120 000	24 700 000
287	310.5	423	371	4 410 000	26 500 000

**SPHERICAL BUSHINGS**

Steel-on-steel Spherical Bushings **Inch Series**



Shaft dia. 12.700 – 63.500mm

Shaft dia. mm (inch)	Identification number		Mass (Ref.) kg	Boundary dimensions mm(inch)			
	Without seal	With seals		<i>d</i>	<i>D</i>	<i>B</i>	<i>C</i>
<b>12.700</b> (1/2)	<b>SBB 8</b>	—	0.020	12.700 (1/2)	22.225 (7/8)	11.10(.437)	9.52(.375)
<b>15.875</b> (5/8)	<b>SBB 10</b>	—	0.036	15.875 (5/8)	26.988 (1 1/16)	13.89(.547)	11.91(.469)
<b>19.050</b> (3/4)	<b>SBB 12</b>	<b>SBB 12-2RS</b>	0.057	19.050 (3/4)	31.750 (1 1/4)	16.66(.656)	14.27(.562)
<b>22.225</b> (7/8)	<b>SBB 14</b>	<b>SBB 14-2RS</b>	0.088	22.225 (7/8)	36.512 (1 7/16)	19.43(.765)	16.66(.656)
<b>25.400</b> (1)	<b>SBB 16</b>	<b>SBB 16-2RS</b>	0.125	25.400 (1)	41.275 (1 5/8)	22.22(.875)	19.05(.750)
<b>31.750</b> (1 1/4)	<b>SBB 20</b>	<b>SBB 20-2RS</b>	0.234	31.750 (1 1/4)	50.800 (2)	27.76(1.093)	23.80(.937)
<b>34.925</b> (1 3/8)	<b>SBB 22</b>	<b>SBB 22-2RS</b>	0.349	34.925 (1 3/8)	55.562 (2 3/16)	30.15(1.187)	26.19(1.031)
<b>38.100</b> (1 1/2)	<b>SBB 24</b>	<b>SBB 24-2RS</b>	0.424	38.100 (1 1/2)	61.912 (2 7/16)	33.32(1.312)	28.58(1.125)
<b>44.450</b> (1 3/4)	<b>SBB 28</b>	<b>SBB 28-2RS</b>	0.649	44.450 (1 3/4)	71.438 (2 13/16)	38.89(1.531)	33.32(1.312)
<b>50.800</b> (2)	<b>SBB 32</b>	<b>SBB 32-2RS</b>	0.939	50.800 (2)	80.962 (3 3/16)	44.45(1.750)	38.10(1.500)
<b>57.150</b> (2 1/4)	<b>SBB 36</b>	<b>SBB 36-2RS</b>	1.32	57.150 (2 1/4)	90.488 (3 9/16)	50.01(1.969)	42.85(1.687)
<b>63.500</b> (2 1/2)	<b>SBB 40</b>	<b>SBB 40-2RS</b>	1.85	63.500 (2 1/2)	100.012 (3 15/16)	55.55(2.187)	47.62(1.875)

Note(1) Maximum allowable corner radius of the shaft or housing  
 Remarks1. The value with mark \* is applicable to types without seals. For types with seals, the value is 0.4 mm.  
 2. The inner ring and the outer ring have an oil groove and two oil holes, respectively.  
 3. No grease is prepacked. Perform proper lubrication.

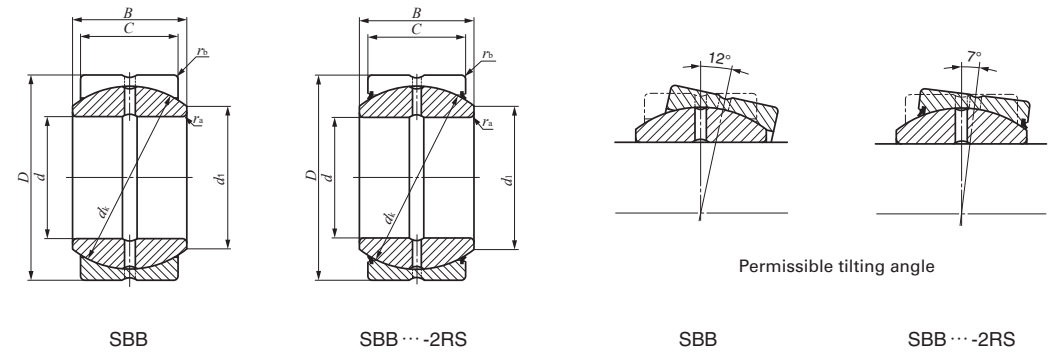

<i>d<sub>k</sub></i>	Radial internal clearance mm Min./Max.	Mounting dimensions mm			Dynamic load capacity <i>C<sub>d</sub></i> N	Static load capacity <i>C<sub>s</sub></i> N
		<i>d<sub>1</sub></i>	<sup>(1)</sup> <i>r<sub>as</sub> max</i> Max.	<sup>(1)</sup> <i>r<sub>bs</sub> max</i> Max.		
18 (.709)	0.05 / 0.15	14.0	0.2	0.6	16 800	101 000
23 (.906)	0.05 / 0.15	17.9	0.2	0.8	26 900	161 000
27.5(1.083)	0.08 / 0.18	21.4	0.6	*0.8	38 500	231 000
32 (1.260)	0.08 / 0.18	25.0	0.6	*0.8	52 300	314 000
36 (1.417)	0.08 / 0.18	28.0	0.6	*0.8	67 300	404 000
45 (1.772)	0.08 / 0.18	35.1	0.6	0.8	105 000	630 000
49 (1.929)	0.08 / 0.18	38.5	0.6	0.8	126 000	755 000
55 (2.165)	0.08 / 0.18	43.3	0.6	0.8	154 000	925 000
64 (2.520)	0.08 / 0.18	50.4	0.6	0.8	209 000	1 250 000
73 (2.874)	0.08 / 0.18	57.6	0.6	0.8	273 000	1 640 000
82 (3.228)	0.10 / 0.20	64.9	0.6	0.8	345 000	2 070 000
91 (3.583)	0.10 / 0.20	72.0	0.6	0.8	425 000	2 550 000

**SPHERICAL BUSHINGS**

Steel-on-steel Spherical Bushings **Inch Series**



Shaft dia. 69.850 – 152.400mm

Shaft dia. mm (inch)	Identification number		Mass (Ref.) kg	Boundary dimensions mm(inch)			
	Without seal	With seals		<i>d</i>	<i>D</i>	<i>B</i>	<i>C</i>
<b>69.850</b> (2¾)	<b>SBB 44</b>	<b>SBB 44-2RS</b>	2.44	69.850 (2¾)	111.125 (4¾)	61.11(2.406)	52.37(2.062)
<b>76.200</b> (3)	<b>SBB 48</b>	<b>SBB 48-2RS</b>	3.12	76.200 (3)	120.650 (4¾)	66.68(2.625)	57.15(2.250)
<b>82.550</b> (3¼)	<b>SBB 52</b>	<b>SBB 52-2RS</b>	3.92	82.550 (3¼)	130.175 (5¼)	72.24(2.844)	61.90(2.437)
<b>88.900</b> (3½)	<b>SBB 56</b>	<b>SBB 56-2RS</b>	4.83	88.900 (3½)	139.700 (5½)	77.77(3.062)	66.68(2.625)
<b>95.250</b> (3¾)	<b>SBB 60</b>	<b>SBB 60-2RS</b>	5.87	95.250 (3¾)	149.225 (5¾)	83.34(3.281)	71.42(2.812)
<b>101.600</b> (4)	<b>SBB 64</b>	<b>SBB 64-2RS</b>	7.07	101.600 (4)	158.750 (6¼)	88.90(3.500)	76.20(3.000)
<b>107.950</b> (4¼)	<b>SBB 68</b>	<b>SBB 68-2RS</b>	8.46	107.950 (4¼)	168.275 (6⅝)	94.46(3.719)	80.95(3.187)
<b>114.300</b> (4½)	<b>SBB 72</b>	<b>SBB 72-2RS</b>	9.94	114.300 (4½)	177.800 (7)	100.00(3.937)	85.72(3.375)
<b>120.650</b> (4¾)	<b>SBB 76</b>	<b>SBB 76-2RS</b>	11.6	120.650 (4¾)	187.325 (7¾)	105.56(4.156)	90.47(3.562)
<b>127.000</b> (5)	<b>SBB 80</b>	<b>SBB 80-2RS</b>	13.5	127.000 (5)	196.850 (7¾)	111.12(4.375)	95.25(3.750)
<b>152.400</b> (6)	<b>SBB 96</b>	<b>SBB 96-2RS</b>	17.6	152.400 (6)	222.250 (8¾)	120.65(4.750)	104.78(4.125)

Note(1) Maximum allowable corner radius of the shaft or housing  
 Remarks1. The inner ring and the outer ring have an oil groove and two oil holes, respectively.  
 2. No grease is prepacked. Perform proper lubrication.

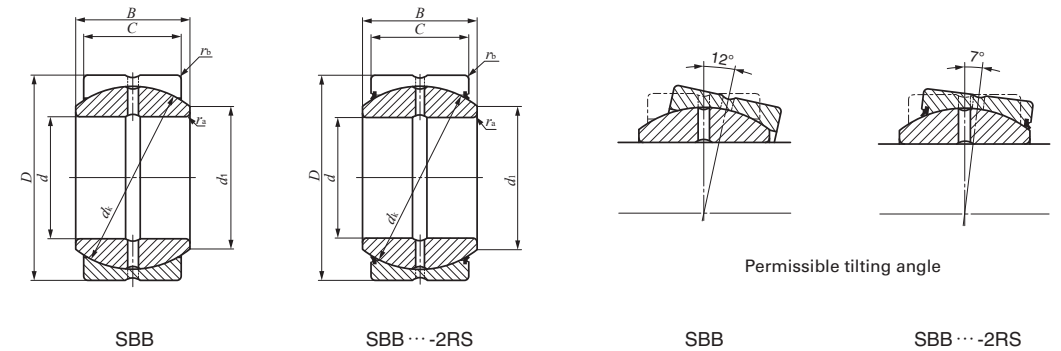

<i>d<sub>k</sub></i>	Radial internal clearance mm Min./Max.	Mounting dimensions mm			Dynamic load capacity <i>C<sub>d</sub></i> N	Static load capacity <i>C<sub>s</sub></i> N
		<i>d<sub>1</sub></i>	<sup>(1)</sup> <i>r<sub>as</sub> max</i> Max.	<sup>(1)</sup> <i>r<sub>bs</sub> max</i> Max.		
100(3.937)	0.10 / 0.20	79.0	0.6	0.8	514 000	3 080 000
110(4.331)	0.10 / 0.20	86.5	0.6	0.8	616 000	3 700 000
119(4.685)	0.13 / 0.23	94.1	0.6	0.8	722 000	4 330 000
128(5.039)	0.13 / 0.23	101.6	0.6	0.8	837 000	5 020 000
137(5.394)	0.13 / 0.23	108.4	0.6	0.8	960 000	5 760 000
146(5.748)	0.13 / 0.23	115.8	0.6	0.8	1 090 000	6 550 000
155(6.102)	0.13 / 0.23	122.6	0.8	1.1	1 230 000	7 380 000
164(6.457)	0.13 / 0.23	129.8	0.8	1.1	1 380 000	8 270 000
173(6.811)	0.13 / 0.23	136.8	0.8	1.1	1 530 000	9 210 000
183(7.205)	0.13 / 0.23	144.9	0.8	1.1	1 710 000	10 300 000
207(8.150)	0.13 / 0.23	167.5	0.8	1.1	2 130 000	12 800 000



**SPHERICAL BUSHINGS**

Maintenance-free Spherical Bushings



Shaft dia. 15 – 70mm

Shaft dia. mm	Identification number		Mass (Ref.) kg	Boundary dimensions mm							Permissible tilting angle degree	
	Without seals	With seals		$d$	$D$	$B$	$C$	$d_k$	$r_{1s \min}^{(1)}$	$r_{2s \min}^{(1)}$	$\alpha$	$\alpha_1$
15	<b>GE 15EC</b>	—	0.032	15	26	12	9	22	0.3	0.3	8	—
17	<b>GE 17EC</b>	—	0.049	17	30	14	10	25	0.3	0.3	10	—
20	<b>GE 20EC</b>	—	0.065	20	35	16	12	29	0.3	0.3	9	—
25	<b>GE 25EC</b>	—	0.115	25	42	20	16	35.5	0.6	0.6	7	—
30	<b>GE 30EC</b>	<b>GE 30EC-2RS</b>	0.160	30	47	22	18	40.7	0.6	0.6	6	4
35	—	<b>GE 35EC-2RS</b>	0.258	35	55	25	20	47	0.6	1	—	4
40	—	<b>GE 40EC-2RS</b>	0.315	40	62	28	22	53	0.6	1	—	4
45	—	<b>GE 45EC-2RS</b>	0.413	45	68	32	25	60	0.6	1	—	4
50	—	<b>GE 50EC-2RS</b>	0.560	50	75	35	28	66	0.6	1	—	4
60	—	<b>GE 60EC-2RS</b>	1.10	60	90	44	36	80	1	1	—	3
70	—	<b>GE 70EC-2RS</b>	1.54	70	105	49	40	92	1	1	—	4

Notes<sup>(1)</sup> Minimum allowable value of chamfer dimensions  $r_1$  and  $r_2$

<sup>(2)</sup> When Spherical Bushings are used with full tilting angle, the shaft shoulder dimension must be less than the maximum value of  $d_a$ .

Remark No oil hole is provided.

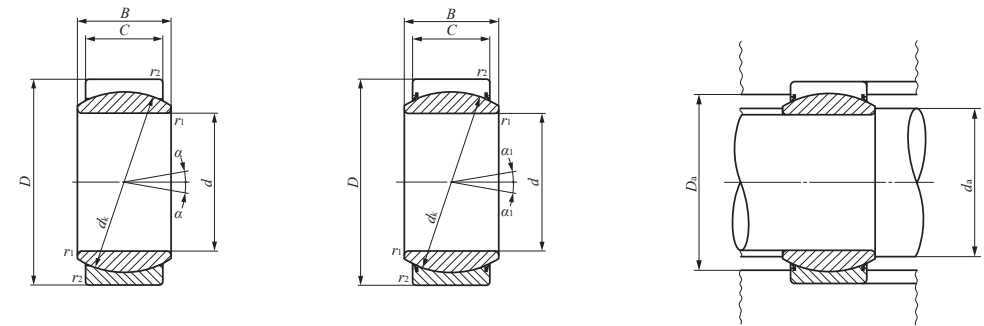

GE...EC

GE...EC-2RS

Mounting dimensions mm				Dynamic load capacity $C_d$ N	Static load capacity $C_s$ N
$d_a$		$D_a$			
Min.	Max. <sup>(2)</sup>	Max.	Min.		
17.5	18	23.5	21.5	19 400	48 500
19.5	20.5	27.5	24.5	24 500	61 300
22.5	24	32.5	28	34 100	85 300
29	29	37.5	34	55 700	139 000
34	34	42.5	41.5	71 800	180 000
39.5	39.5	49.5	48	92 200	230 000
44.5	45	56.5	54.5	114 000	286 000
49.5	50.5	62.5	60	147 000	368 000
54.5	56	69.5	66	181 000	453 000
65.5	66.5	84.5	79	282 000	706 000
75.5	77.5	99.5	91	361 000	902 000

# PILLOBALLS

- PILLOBALL Spherical Bushings - Insert Type
- PILLOBALL Rod Ends - Insert Type
- PILLOBALL Rod Ends - Die-cast Type
- PILLOBALL Rod Ends - Maintenance-free Type



## Structure and Features

IKO PILLOBALLS are compact self-aligning spherical bushings that can support a large radial load and a bi-directional axial load at the same time. These bushings are classified by sliding surface types, namely, insert type, die-cast type and maintenance-free type. In the insert type, a spherical inner ring makes contact with the special copper alloy bushing with superior run-in properties. In the die-cast type, a spherical inner ring makes direct contact with the bore surface of the body of special zinc die-cast alloy. In the maintenance-free type, a spherical inner ring makes contact with the special PTFE liner of maintenance-free type. Thus, a smooth rotational and oscillatory motion can be achieved with superior anti-wear and loading properties in each type. PILLOBALL Rod Ends have either a female thread in the body or a male thread on the body, and they can be easily assembled onto machines. PILLOBALLS are used in control and link mechanisms in machine tools, textile machines, packaging machines, etc. The maintenance-free type is especially suitable for loading in one direction and is the best choice for machines in which oil must be avoided such as food processing machines, or machines which cannot be re-lubricated.

### Structures of maintenance-free type PILLOBALLS

#### PHS···EC

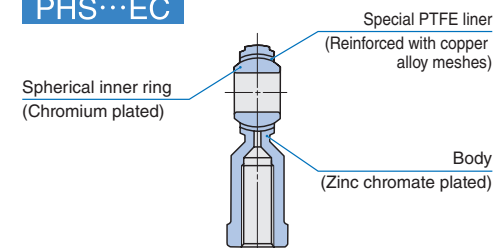

#### POS···EC

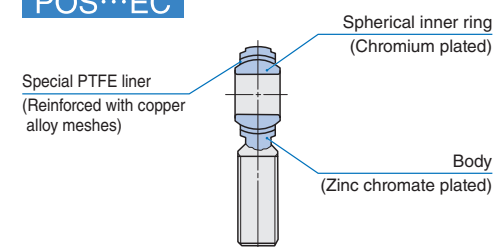

### Structures of lubrication type PILLOBALLS

#### PB

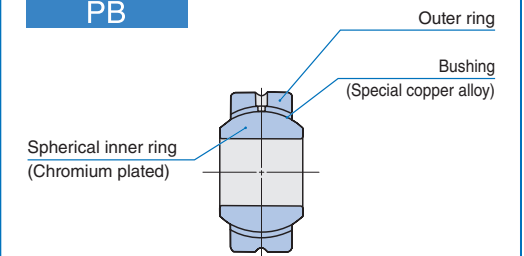

#### PHS(···A)·PHSB

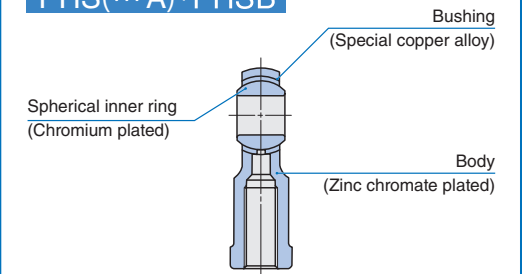

#### POS(···A)·POSB

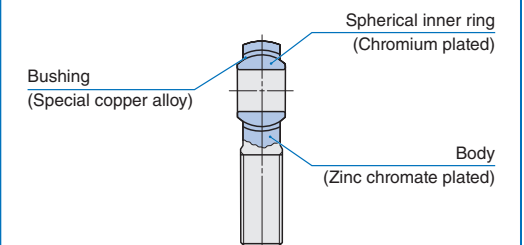

#### PHSA

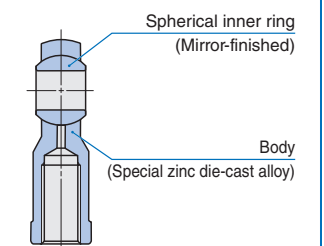

K

PB  
PHS  
PHSB  
POS  
POSB  
PHSA

## Types

In PILLOBALLs, the types shown in Table 1 are available.

Table 1 Type

Type	Lubrication type		Maintenance-free type		
	Spherical Bushings	Rod end	Rod end		
Insert type	PB	PHS(···A) · PHSB	POS(···A) · POSB	PHS···EC	POS···EC
Die-cast type	—	PHSA	—	—	—

### Lubrication Type PILLOBALL Spherical Bushings Insert Type PB

This type has superior anti-wear properties and high rigidity. It consists of a spherical inner ring, an outer ring, and a bushing of special copper alloy with superior run-in properties inserted in between. The spherical surface of the inner ring is chromium plated after heat treatment and grinding. This type is assembled with a shaft and a housing.

When especially large radial and/or axial loads are applied, Spherical Bushings with molybdenum disulfide (MoS<sub>2</sub>) treated inner and outer rings are recommended. (See page K1.)

### Lubrication Type PILLOBALL Rod Ends Insert Type PHS(···A), POS(···A), PHSB and POSB

This type has superior wear-resistant and corrosion-resistant properties as well as high rigidity. It consists of a spherical inner ring of which the spherical surface is chromium plated after heat treatment and grinding, a body with a zinc chromate plated outer surface, and an inserted bushing of special copper alloy having superior run-in properties. PHS, which has a female thread in the body, and POS, which has a male thread on the body, are available. For PHS and POS sizes 5 to 18, an A is appended after the dimensions as a model code.

### Lubrication Type PILLOBALL Rod Ends Die-cast Type PHSA

The spherical inner ring of this type is mirror-finished after heat treatment and is built in a body of special zinc die-cast alloy. The sliding surfaces of the inner ring and body are in close contact with each other. Thus, this type is an economical rod end with superior anti-wear and loading properties.

### Maintenance-free Type PILLOBALL Rod Ends PHS···EC, POS···EC

This type has superior anti-corrosion properties as the

body is zinc chromate treated and the spherical inner ring is chromium plated on the sphere surface after heat treatment and grinding.

A special PTFE liner, reinforced with copper alloy meshes, which is superior in anti-wear properties with little creep deformation is used for lining on the sliding surface of the body, and this type is maintenance-free.

PHS···EC, which has a female thread in the body, and POS···EC, which has a male thread on the body, are available.

## Identification number

The identification number of PILLOBALLs consists of a model code, a size and any supplemental codes as shown in the examples.

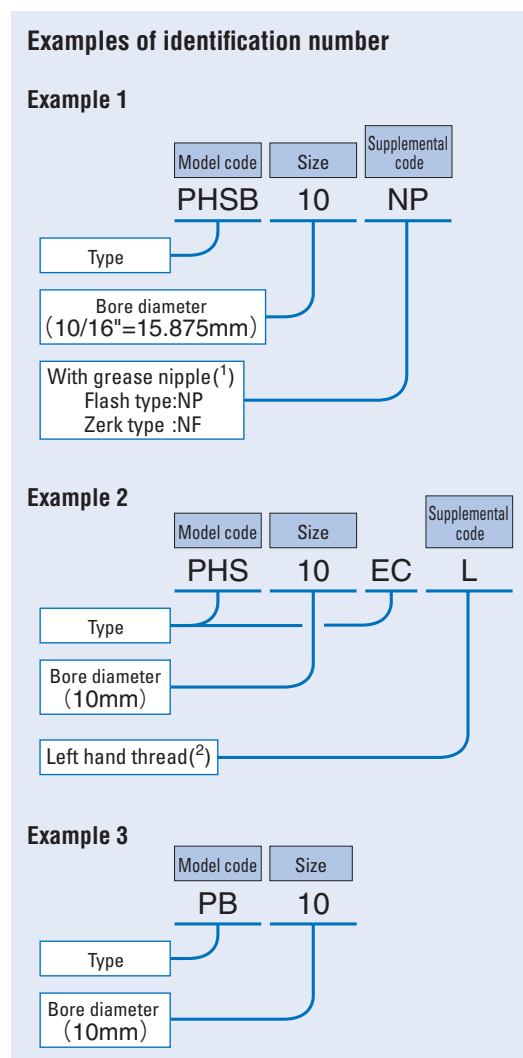

Notes<sup>(1)</sup> Shapes of grease nipple are shown in Fig.1. In case of no indication of grease nipple type, grease nipple is not prepared.  
<sup>(2)</sup> Right hand thread is indicated with no code.

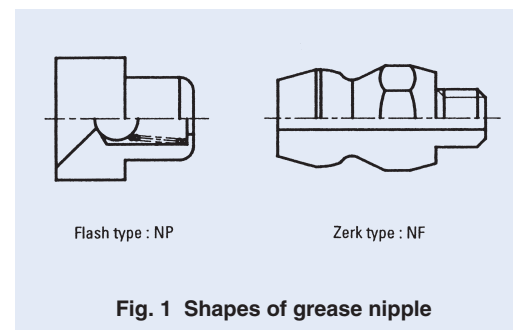

Fig. 1 Shapes of grease nipple

## Accuracy

The accuracy of PILLOBALLs is shown in Tables 2 and 3. The maximum radial internal clearance of the insert type is 0.035 mm.

Table 2 Tolerance unit: mm

Type	Dimension	Dimension symbol	Tolerance
PB	Bore dia. of inner ring	<i>d</i>	H7
	Outside dia. of outer ring	<i>D</i>	h6
	Width of inner ring	<i>B</i>	0 - 0.1
	Width of outer ring	<i>C</i>	± 0.1
PHS(···A) POS(···A) PHS···EC POS···EC	Bore dia. of inner ring	<i>d</i>	H7
	Width of inner ring	<i>B</i>	0 - 0.1
	Bore dia. of inner ring	<i>d</i>	+ 0.038 - 0.013
PHSB POSB	Width of inner ring	<i>B</i> <sub>1</sub>	0 - 0.127
	PHSA	Bore dia. of inner ring	<i>d</i>
Width of inner ring		<i>B</i>	See Table 3.

Table 3 Tolerance of width *B* of inner ring of PHSA type unit: mm

<i>d</i>	$\Delta_{Bs}$			
	Nominal bore dia. of inner ring		Deviation of a single inner ring width	
Over	Incl.	High	Low	
—	14	0	- 0.2	
14	20	0	- 0.3	
20	22	0	- 0.4	

## Fit

Recommended fits for PILLOBALLs are shown in Table 4.

Table 4 Recommended fits

Condition	Tolerance class	
	Shaft	Housing bore <sup>(1)</sup>
Normal operation	h7	H7
Directionally indeterminate loading	n6, p6	N7

Note<sup>(1)</sup> This is applicable to PILLOBALL Spherical Bushings, Insert type.

## Selection of PILLOBALL

Load capacities of PILLOBALLs are determined based on the allowable contact pressure on sliding surfaces and the strength of body for each type. Thus, a suitable type and size should be selected based on the dynamic load capacity *C<sub>d</sub>* and static load capacity *C<sub>s</sub>* shown in the dimension tables.

### Load capacity

#### ① Dynamic load capacity

The dynamic load capacity *C<sub>d</sub>* is obtained on the basis of the contact pressure on the sliding surface. The dynamic load capacity is used for calculating the life.

The dynamic load capacity considering temperature increase is obtained from the following equation using the temperature factor, which is a correction factor for the effect of PILLOBALL temperature.

$$C_{dt} = f_t C_d \quad \text{.....(1)}$$

where, *C<sub>dt</sub>*: Dynamic load capacity considering temperature increase, N

*f<sub>t</sub>*: Temperature factor (Refer to Table 5.)

*C<sub>d</sub>*: Dynamic load capacity, N (Refer to the dimension tables.)

Table 5 Temperature factor *f<sub>t</sub>*

Type	Temperature °C					
	- 30 + 80	+ 80 + 90	+ 90 + 100	+ 100 + 120	+ 120 + 150	+ 150 + 180
PB PHS(···A), POS(···A) PHSB, POSB	1	1	1	1	1	0.7
PHS···EC POS···EC	1	1	0.9	0.75	0.55	—

#### ② Static load capacity

The static load capacity *C<sub>s</sub>* is the maximum static load that can be applied on the PILLOBALL without breaking the inner or outer ring of the PILLOBALL Spherical Bushing (or the inner ring or body of the PILLOBALL Rod End), and without causing severe permanent deformation that will make the PILLOBALL unusable.



**Maximum Operating Load**

The recommended value of bushing load is obtained by multiplying the dynamic load capacity  $C_d$  by a numerical factor, which differs depending on the bushing type and load condition. For PILLOBALL Rod Ends, the static load capacity  $C_s$  must also be considered in determining the applicable bushing load. Table 6 shows the guidelines for maximum operating load of PILLOBALLS. When axial loads are added in addition to radial loads, bending stress occurs in the body. Pay attention to this bending stress.

**Table 6 Maximum operating load**

Type	Load direction	
	Constant	Alternate
PB	$\leq 0.3C_d$	$\leq 0.6C_d$
PHS(-A), POS(-A), PHSB, POSB	$\leq 0.3C_d$	$\leq 0.2C_s$
PHSA	$\leq 0.16C_s$	
PHS...EC, POS...EC	$\leq 0.3C_s$	$\leq 0.2C_s$

Remark  $C_d$  is the dynamic load capacity and  $C_s$  is the static load capacity.

**Equivalent radial load**

PILLOBALLS can take radial and axial loads at the same time. When the magnitude and direction of loads are constant, the equivalent radial load can be obtained by the following equation.

$$P = F_r + YF_a \quad (2)$$

where,  $P$ : Equivalent radial load, N  
 $F_r$ : Radial load, N  
 $F_a$ : Axial load, N  
 $Y$ : Axial load factor (Refer to Table 7.)

**Table 7 Axial load factor Y**

Type	$F_a/F_r$	0.1	0.2	0.3	0.4	0.5	> 0.5
PB		1	2	3	4	5	Unusable
PHS(-A), POS(-A), PHSB, POSB		1	2	3	4	5	Unusable
PHS...EC, POS...EC		1	2	3	Unusable		

**Life**

The life of PILLOBALLS is defined as the total number of oscillating motions during which the PILLOBALLS can be operated without failure or malfunction due to wear, increase in internal clearance, increase in sliding torque and operating temperature, etc.

As the actual life is affected by many factors such as the material of the sliding surface, the magnitude and direction of load, lubrication, sliding velocity, etc., the calculated life can be used as a measure of expected service life.

**① Life of lubrication type PILLOBALLS**  
**PB · PHS(…A) · POS(…A) · PHSB · POSB**

[1] Confirmation of  $pV$  value  
 Before attempting to calculate the life, make sure that the operating conditions are within the permissible range by referring to the  $pV$  diagram in Fig.2.

When the operating conditions are out of the permissible range, please consult IKO.

The contact pressure  $p$  and the sliding velocity  $V$  are obtained from the following equations.

$$p = \frac{50P}{C_{dt}} \quad (3)$$

$$V = 5.82 \times 10^{-4} d_k \beta f \quad (4)$$

where,  $p$ : Contact pressure, N/mm<sup>2</sup>  
 $P$ : Equivalent radial load, N  
 (Refer to equation (2).)

$C_{dt}$ : Dynamic load capacity considering temperature increase, N  
 (Refer to equation (1).)

$V$ : Sliding velocity, mm/s

$d_k$ : Sphere diameter, mm  
 (Refer to the dimensional tables.)

$2\beta$ : Oscillating angle degrees (Refer to Fig.3.)  
 when  $\beta < 5^\circ$ ,  $\beta = 5$   
 when rotating,  $\beta = 90$

$f$ : Number of oscillations per minute, min<sup>-1</sup>

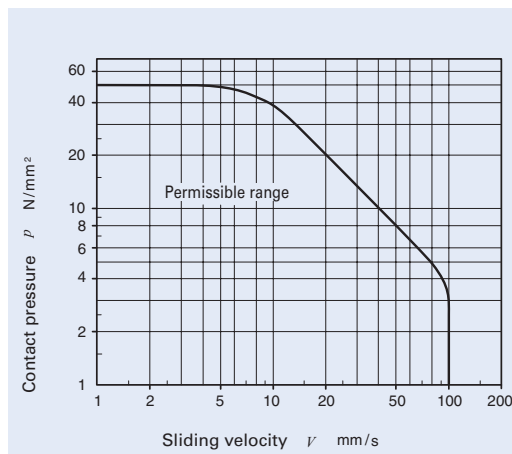

**Fig. 2 pV diagram of lubrication type PILLOBALLS**

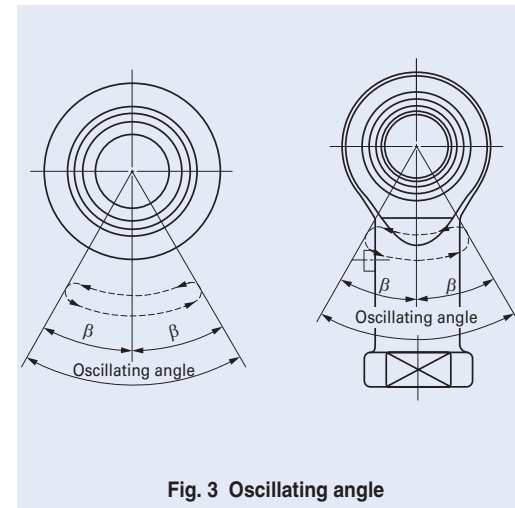

**Fig. 3 Oscillating angle**

[2] Life calculation

The life of lubrication type PILLOBALLS can be calculated by the following equations.

$$G = \frac{3.18b_1b_2b_3}{\sqrt{d_k \beta}} \left(\frac{C_{dt}}{P}\right)^2 \times 10^5 \quad (5)$$

$$L_h = \frac{G}{60f} \quad (6)$$

where,  $G$ : Life (Total number of oscillations)  
 $b_1$ : Load directional factor (Refer to Table 8.)  
 $b_2$ : Lubrication factor (Refer to Table 8.)  
 $b_3$ : Sliding velocity factor (Refer to Fig. 4.)  
 $C_{dt}$ : Dynamic load capacity considering temperature increase, N  
 (Refer to equation (1).)  
 $P$ : Equivalent radial load, N  
 (Refer to equation (2).)  
 $L_h$ : Life in hours, h  
 $f$ : Number of oscillations per minute, min<sup>-1</sup>

**Table 8 Load directional factor  $b_1$  and lubrication factor  $b_2$  for lubrication type PILLOBALLS**

Load directional factor $b_1$		Lubrication factor $b_2$	
Load direction		Periodical lubrication	
Constant	Alternate	None	Regular
1	5	1	15

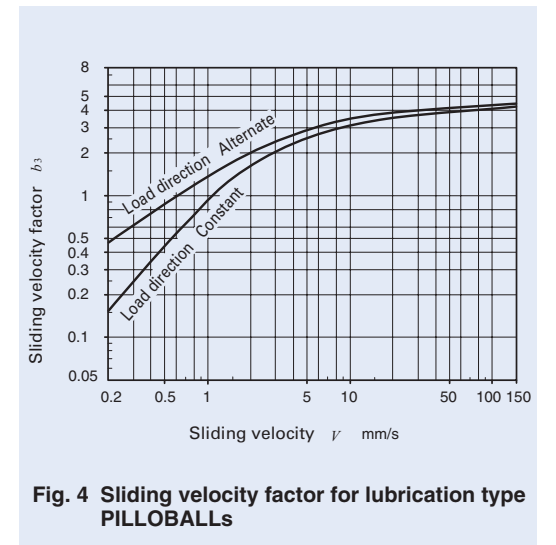

**Fig. 4 Sliding velocity factor for lubrication type PILLOBALLS**

**② Life of maintenance-free type PILLOBALLS** PHS...EC · POS...EC

[1] Confirmation of  $pV$  value  
 Before attempting to calculate the life, make sure that the operating conditions are within the permissible range by referring to the  $pV$  diagram in Fig.5.

When the operating conditions are out of the permissible range, please consult IKO.

The contact pressure  $p$  and sliding velocity  $V$  are obtained from equations (3) and (4).

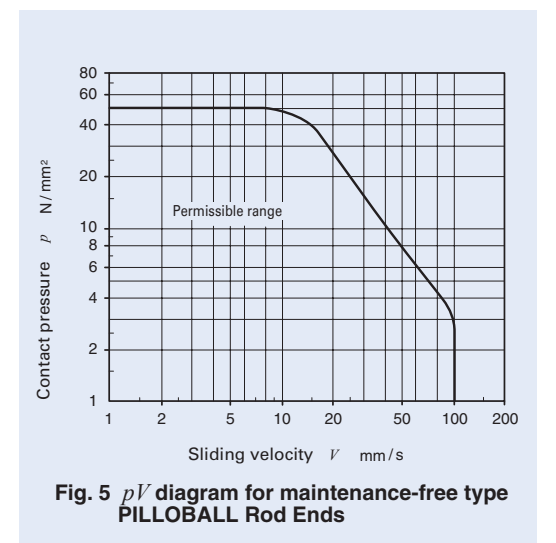

**Fig. 5 pV diagram for maintenance-free type PILLOBALL Rod Ends**

K  
 PB  
 PHS  
 PHSB  
 POS  
 POSB  
 PHSA



[2] Life calculation

The life of maintenance-free type PILLOBALL Rod Ends is obtained from the total sliding distance  $S$  which is given in Fig.6 for the contact pressure  $p$  obtained from equation (3).

The total number of oscillations and life in hours can be obtained from the following equations.

$$G = 16.67 \times b_1 \times \frac{Sf}{V} \dots\dots\dots(7)$$

$$L_h = \frac{G}{60f} \dots\dots\dots(8)$$

where,  $G$  : Life (Total number of oscillations)  
 $b_1$  : Load directional factor (Refer to Table 9.)  
 $S$  : Total sliding distance m  
 $f$  : Number of oscillations per minute min<sup>-1</sup>  
 $V$  : Sliding velocity mm/s  
 $L_h$  : Life in hours h

Table 9 Load directional factor for maintenance-free type PILLOBALLs  $b_1$

Load direction	Constant	Alternate
Load directional factor $b_1$	1	0.2 <sup>(1)</sup>

Note<sup>(1)</sup> This value is applicable when the load changes comparatively slowly. When the load changes rapidly, please consult IKO, as the factor decreases sharply.

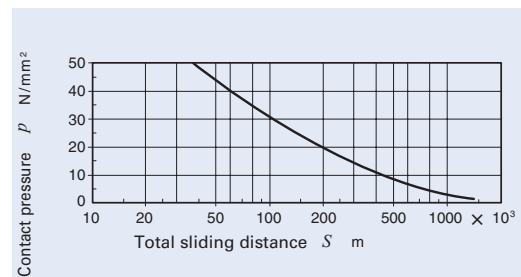

Fig. 6 Contact pressure and total sliding distance for maintenance-free type PILLOBALL Rod Ends

**Lubrication**

Maintenance-free type PILLOBALL Rod Ends have a sliding surface lined with a self-lubricating lining. Therefore, they can be used without lubrication. Lubrication type PILLOBALLs are not provided with prepacked grease. Perform proper lubrication for use. Operating without lubrication will increase the wear of the sliding contact surfaces and cause seizure.

**Oil Hole and Grease Nipple**

Table 10 shows the specifications of oil hole and grease nipple on the outer ring or body. Further, lubrication nozzle models compatible with the grease nipple are shown in Table 11.

For PILLOBALLs without an oil hole and grease nipple, apply grease directly on the spherical surface.

Table 10 Specifications of oil hole and grease nipple

Type	Specification	
	Bore diameter of inner ring $d$ mm	
PB		1 oil hole + oil groove
PHS(…A)	$d \leq 4$	None
	$4 < d$	With grease nipple
POS(…A)	$d \leq 4$	None
	$4 < d \leq 6$	1 oil hole
	$6 < d$	With grease nipple
PHSB · POSB		None <sup>(1)</sup>
PHSA		With grease nipple
PHS … EC, POS … EC		None

Note<sup>(1)</sup> Grease Nipple is available for size 4 or larger with supplemental code.

Table 11 Types and Dimension of Lubrication Nozzles

Type	Dimension
A-5126T	
A-5120R	
B-5120R	

Remark HSP-3(Yamada Corporation)can be used for them. The above nozzles can be attached on the standard grease gun shown below.

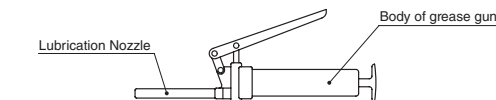

**Operating Temperature Range**

The maximum allowable temperature for Lubrication type PILLOBALLs is +180°C for the insert type and +80°C for the die-cast type.

The maximum allowable temperature for Maintenance-free type PILLOBALL Rod Ends is +150°C.

**Precautions for Use**

**1 Tightening depth**

The recommended tightening depth of the screw into the PILLOBALL Rod End body is shown below.

Insert type and maintenance-free type: 1.25 times the nominal thread dia. or more.

Die-cast type: 2 times the nominal thread dia. or more.

**2 Allowable tilting angle**

The allowable tilting angle differs depending on the mounting structure as shown in Table 12 and Table 13.

Table 12 Allowable tilting angle

unit: degree

$d$ Bore diameter mm	PB <sup>(1)</sup> , PHS(…A), POS(…A) PHS … EC, POS … EC		PHSA	
	$\alpha_1$	$\alpha_2$	$\alpha_1$	$\alpha_2$
3	7	13	—	—
4	7	13	—	—
5	8	13	7	13
6	8	13	7	13
8	8	14	8	14
10	8	14	8	14
12	8	13	8	13
14	10	16	9	16
16	9	15	9	15
18	9	15	9	15
20	9	15	9	15
22	10	15	9	15
25	9	15	—	—
28	9	15	—	—
30	10	17	—	—

Note<sup>(1)</sup> In the case of the PB series,  $\alpha_2$  is applicable in general.

Table 13 Allowable tilting angle for inch series

unit: degree

With female thread	With male thread	$\alpha_1$	$\alpha_2$
PHSB 2	POSB 2	8	16
PHSB 2.5	POSB 2.5	7	12
PHSB 3	POSB 3	6	10
PHSB 4	POSB 4	7	13
PHSB 5	POSB 5	6	10
PHSB 6	POSB 6	6	11
PHSB 7	POSB 7	7	11
PHSB 8	POSB 8	6	9
PHSB 10	POSB 10	7	11
PHSB 12	POSB 12	6	10
PHSB 16	POSB 16	7	14



Lubrication Type PILLOBALL Spherical Bushings **Insert Type**

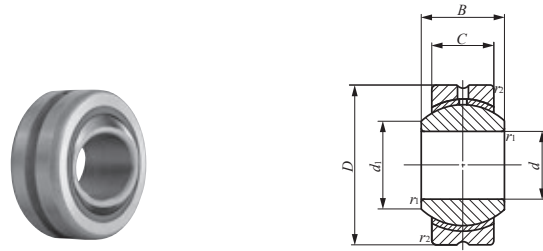

PB

Identification number	Mass (Ref.) g	Boundary dimensions mm							Dynamic load capacity $C_d$ N	Static load capacity $C_s$ N
		$d$	$D$	$C$	$B$	$d_1$	$r_{s \min}^{(1)}$	Ball dia. mm (inch)		
PB 5	8.5	5	16	6	8	7.7	0.2	11.112 ( $\frac{7}{16}$ )	3 270	7 850
PB 6	13	6	18	6.75	9	9	0.2	12.700 ( $\frac{1}{2}$ )	4 200	10 100
PB 8	24	8	22	9	12	10.4	0.2	15.875 ( $\frac{5}{8}$ )	7 010	16 800
PB 10	39	10	26	10.5	14	12.9	0.2	19.050 ( $\frac{3}{4}$ )	9 810	23 500
PB 12	58	12	30	12	16	15.4	0.2	22.225 ( $\frac{7}{8}$ )	13 100	31 400
PB 14	84	14	34	13.5	19	16.9	0.3	25.400 (1)	16 800	40 400
PB 16	111	16	38	15	21	19.4	0.3	28.575 ( $1\frac{1}{8}$ )	21 000	50 400
PB 18	160	18	42	16.5	23	21.9	0.3	31.750 ( $1\frac{1}{4}$ )	25 700	61 600
PB 20	210	20	46	18	25	24.4	0.3	34.925 ( $1\frac{3}{8}$ )	30 800	74 000
PB 22	265	22	50	20	28	25.8	0.3	38.100 ( $1\frac{1}{2}$ )	37 400	89 700
PB 25	390	25	56	22	31	29.6	0.6	42.862 ( $1\frac{11}{16}$ )	46 200	111 000
PB 28	410	28	62	25	35	32.3	0.6	47.625 ( $1\frac{7}{8}$ )	58 400	140 000
PB 30	610	30	66	25	37	34.8	0.6	50.800 (2)	62 300	149 000

Note<sup>(1)</sup> Minimum allowable value of chamfer dimensions  $r_1$  and  $r_2$   
 Remarks1. The outer ring has an oil groove and an oil hole.  
 2. No grease is prepacked. Perform proper lubrication.

Lubrication Type PILLOBALL Rod Ends **Insert Type/With Female Thread**

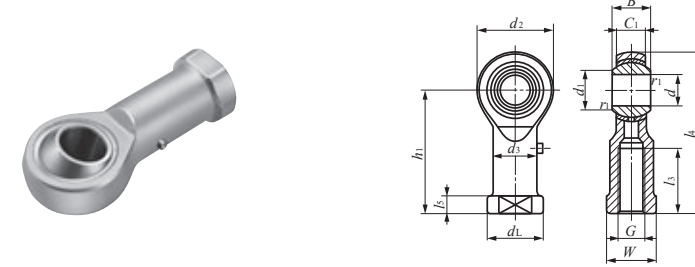

PHS(...A)

Identification number	Mass (Ref.) g	Boundary dimensions mm															Dynamic load capacity $C_d$ N	Static load capacity $C_s$ N
		$d$	Thread $G$	$d_2$	$C_1$	$B$	$d_1$	$l_4$	$h_1$	$l_3$	$l_5$	$W$	$d_3$	$d_L$	$r_{1smin}^{(1)}$	Ball dia. mm (inch)		
PHS 3	5.7	3	M 3×0.5	12	4.5	6	5.2	27	21	10	3	5.5	5	6.5	0.2	7.938 ( $\frac{5}{16}$ )	1 750	3 670
PHS 4	11.9	4	M 4×0.7	14	5.3	7	6.5	31	24	12	4	8	8	9.5	0.2	9.525 ( $\frac{3}{8}$ )	2 480	4 680
PHS 5A	16.5	5	M 5×0.8	16	6	8	7.7	35	27	14	4	9	9	11	0.2	11.112 ( $\frac{7}{16}$ )	3 270	5 730
PHS 6A	25	6	M 6×1	18	6.75	9	9	39	30	14	5	11	10	13	0.2	12.700 ( $\frac{1}{2}$ )	4 200	6 910
PHS 8A	43	8	M 8×1.25	22	9	12	10.4	47	36	17	5	14	12.5	16	0.2	15.875 ( $\frac{5}{8}$ )	7 010	10 200
PHS 10A	72	10	M10×1.5	26	10.5	14	12.9	56	43	21	6.5	17	15	19	0.2	19.050 ( $\frac{3}{4}$ )	9 810	13 300
PHS 12A	107	12	M12×1.75	30	12	16	15.4	65	50	24	6.5	19	17.5	22	0.2	22.225 ( $\frac{7}{8}$ )	13 100	16 900
PHS 14A	160	14	M14×2	34	13.5	19	16.9	74	57	27	8	22	20	25	0.2	25.400 (1)	16 800	20 900
PHS 16A	210	16	M16×2	38	15	21	19.4	83	64	33	8	22	22	27	0.2	28.575 ( $1\frac{1}{8}$ )	21 000	25 400
PHS 18A	295	18	M18×1.5	42	16.5	23	21.9	92	71	36	10	27	25	31	0.2	31.750 ( $1\frac{1}{4}$ )	25 700	30 200
PHS 20	380	20	M20×1.5	46	18	25	24.4	100	77	40	10	30	27.5	34	0.2	34.925 ( $1\frac{3}{8}$ )	30 800	35 500
PHS 22	490	22	M22×1.5	50	20	28	25.8	109	84	43	12	32	30	37	0.2	38.100 ( $1\frac{1}{2}$ )	37 400	41 700
PHS 25	750	25	M24×2	60	22	31	29.6	124	94	48	12	36	33.5	42	0.6	42.862 ( $1\frac{11}{16}$ )	46 200	72 700
PHS 28	950	28	M27×2	66	25	35	32.3	136	103	53	12	41	37	46	0.6	47.625 ( $1\frac{7}{8}$ )	58 400	87 000
PHS 30	1 130	30	M30×2	70	25	37	34.8	145	110	56	15	41	40	50	0.6	50.800 (2)	62 300	92 200

Note<sup>(1)</sup> Minimum allowable value of chamfer dimension  $r_1$   
 Remarks1. Neither oil hole nor grease nipple is provided for PHS with an inner ring bore diameter  $d$  of 4 mm or less.  
 For others, a grease nipple is provided on the body.  
 2. No grease is prepacked. Perform proper lubrication.  
 3. When a metric fine thread specification for inner ring bore diameter  $d$  of 8 mm to 14 mm is required, please contact IKO.

Lubrication Type PILLOBALL Rod Ends **Insert Type/With Male Thread**

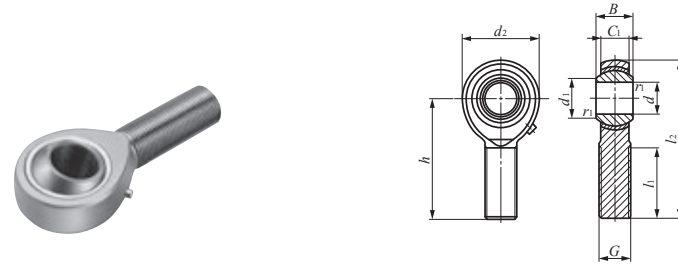

POS(···A)

Identification number	Mass (Ref.) g	Boundary dimensions mm											Dynamic load capacity Cd N	Static load capacity Cs N
		d	Thread G	d2	C1	B	d1	l2	h	l1	r1smin <sup>(1)</sup>	Ball dia. mm (inch)		
POS 3	5.0	3	M 3×0.5	12	4.5	6	5.2	33	27	15	0.2	7.938 ( 5/16 )	1 750	1 220
POS 4	8.1	4	M 4×0.7	14	5.3	7	6.5	37	30	17	0.2	9.525 ( 3/8 )	2 480	2 060
POS 5A	12.5	5	M 5×0.8	16	6	8	7.7	41	33	20	0.2	11.112 ( 7/16 )	3 270	3 340
POS 6A	19	6	M 6×1	18	6.75	9	9	45	36	22	0.2	12.700 ( 1/2 )	4 200	4 730
POS 8A	32	8	M 8×1.25	22	9	12	10.4	53	42	25	0.2	15.875 ( 5/8 )	7 010	8 640
POS 10A	54	10	M10×1.5	26	10.5	14	12.9	61	48	29	0.2	19.050 ( 3/4 )	9 810	13 300
POS 12A	85	12	M12×1.75	30	12	16	15.4	69	54	33	0.2	22.225 ( 7/8 )	13 100	16 900
POS 14A	126	14	M14×2	34	13.5	19	16.9	77	60	36	0.2	25.400 ( 1 )	16 800	20 900
POS 16A	185	16	M16×2	38	15	21	19.4	85	66	40	0.2	28.575 ( 1 1/8 )	21 000	25 400
POS 18A	260	18	M18×1.5	42	16.5	23	21.9	93	72	44	0.2	31.750 ( 1 1/4 )	25 700	30 200
POS 20	340	20	M20×1.5	46	18	25	24.4	101	78	47	0.2	34.925 ( 1 3/8 )	30 800	35 500
POS 22	435	22	M22×1.5	50	20	28	25.8	109	84	51	0.2	38.100 ( 1 1/2 )	37 400	41 700
POS 25	650	25	M24×2	60	22	31	29.6	124	94	57	0.6	42.862 ( 1 11/16 )	46 200	72 700
POS 28	875	28	M27×2	66	25	35	32.3	136	103	62	0.6	47.625 ( 1 7/8 )	58 400	87 000
POS 30	1 070	30	M30×2	70	25	37	34.8	145	110	66	0.6	50.800 ( 2 )	62 300	92 200

Note<sup>(1)</sup> Minimum allowable value of chamfer dimension r<sub>1</sub>

Remarks1. Neither oil hole nor grease nipple is provided for POS with an inner ring bore diameter d of 4 mm or less.

For those with an inner ring bore diameter d of 5 to 6 mm, an oil hole is provided on the body. For others, a grease nipple is provided on the body.

2. No grease is prepacked. Perform proper lubrication.

3. When a metric fine thread specification for inner ring bore diameter d of 8 mm to 14 mm is required, please contact IKO.

Inch series PILLOBALL Rod Ends **Insert Type/With Female Thread**

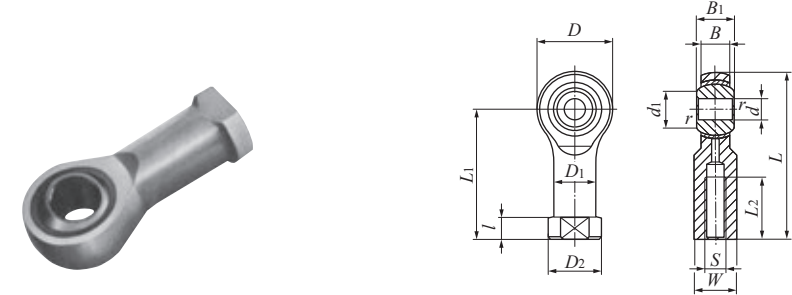

PHSB

Identification number	Mass (Ref.) g	Boundary dimensions mm(inch)																Dynamic load capacity Cd N	Static load capacity Cs N
		d	Thread S class 3B	D	B	B1	d1	L	l	L1	L2	W	D1	D2	r <sub>smin</sub> <sup>(1)</sup>	Ball dia. mm (inch)			
PHSB 2	6.8	3.175 ( .1250 )	-32UNC ( .1380 )	11.91 ( .469 )	4.75 ( .187 )	6.35 ( .250 )	4.75 ( .187 )	26.57 ( 1.046 )	4.75 ( .187 )	20.62 ( .812 )	9.53 ( .375 )	6.35 ( .250 )	6.35 ( .250 )	7.92 ( .312 )	0.3 ( .012 )	7.938 ( 5/16 )	1 850	5 840	
PHSB 2.5	11	3.967 ( .1562 )	-32UNC ( .1640 )	14.27 ( .562 )	5.56 ( .219 )	7.14 ( .281 )	6.32 ( .249 )	29.36 ( 1.156 )	4.75 ( .187 )	22.23 ( .875 )	9.53 ( .375 )	7.14 ( .281 )	7.14 ( .281 )	8.74 ( .344 )	0.3 ( .012 )	9.525 ( 3/8 )	2 600	8 210	
PHSB 3	14	4.826 ( .1900 )	-32UNF ( .1900 )	15.88 ( .625 )	6.35 ( .250 )	7.92 ( .312 )	7.77 ( .306 )	34.93 ( 1.375 )	4.75 ( .187 )	26.97 ( 1.062 )	14.27 ( .562 )	7.92 ( .312 )	7.92 ( .312 )	10.31 ( .406 )	0.3 ( .012 )	11.112 ( 7/16 )	3 460	9 090	
PHSB 4	23	6.350 ( .2500 )	-28UNF ( .2500 )	19.05 ( .750 )	7.14 ( .281 )	9.53 ( .375 )	9.02 ( .355 )	42.85 ( 1.687 )	4.75 ( .187 )	33.32 ( 1.312 )	19.05 ( .750 )	9.53 ( .375 )	9.53 ( .375 )	11.89 ( .468 )	0.5 ( .020 )	13.097 ( 33/64 )	4 590	13 200	
PHSB 5	36	7.938 ( .3125 )	-24UNF ( .3125 )	22.23 ( .875 )	8.74 ( .344 )	11.10 ( .437 )	11.35 ( .447 )	46.02 ( 1.812 )	4.75 ( .187 )	34.93 ( 1.375 )	19.05 ( .750 )	11.10 ( .437 )	11.10 ( .437 )	12.70 ( .500 )	0.5 ( .020 )	15.875 ( 5/8 )	6 800	16 500	
PHSB 6	59	9.525 ( .3750 )	-24UNF ( .3750 )	25.40 ( 1.000 )	10.31 ( .406 )	12.70 ( .500 )	13.13 ( .517 )	53.98 ( 2.125 )	6.35 ( .250 )	41.28 ( 1.625 )	23.80 ( .937 )	14.27 ( .562 )	14.27 ( .562 )	17.45 ( .687 )	0.5 ( .020 )	18.256 ( 23/32 )	9 230	21 600	
PHSB 7	82	11.112 ( .4375 )	-20UNF ( .4375 )	28.58 ( 1.125 )	11.10 ( .437 )	14.27 ( .562 )	14.88 ( .586 )	60.33 ( 2.375 )	6.35 ( .250 )	46.02 ( 1.812 )	26.97 ( 1.062 )	15.88 ( .625 )	15.88 ( .625 )	19.05 ( .750 )	0.5 ( .020 )	20.638 ( 13/16 )	11 200	26 100	
PHSB 8	132	12.700 ( .5000 )	-20UNF ( .5000 )	33.32 ( 1.312 )	12.70 ( .500 )	15.88 ( .625 )	17.73 ( .698 )	70.64 ( 2.781 )	6.35 ( .250 )	53.98 ( 2.125 )	30.15 ( 1.187 )	19.05 ( .750 )	19.05 ( .750 )	22.23 ( .875 )	0.5 ( .020 )	23.812 ( 15/16 )	14 800	36 200	
PHSB 10	191	15.875 ( .6250 )	-18UNF ( .6250 )	38.10 ( 1.500 )	14.27 ( .562 )	19.05 ( .750 )	21.31 ( .839 )	82.55 ( 3.250 )	7.92 ( .312 )	63.50 ( 2.500 )	38.10 ( 1.500 )	22.23 ( .875 )	22.23 ( .875 )	25.40 ( 1.000 )	0.5 ( .020 )	28.575 ( 1 1/8 )	20 000	39 300	
PHSB 12	286	19.050 ( .7500 )	-16UNF ( .7500 )	44.45 ( 1.750 )	17.45 ( .687 )	22.23 ( .875 )	24.84 ( .978 )	95.25 ( 3.750 )	7.92 ( .312 )	73.03 ( 2.875 )	44.45 ( 1.750 )	25.40 ( 1.000 )	25.40 ( 1.000 )	28.58 ( 1.125 )	0.5 ( .020 )	33.338 ( 1 1/16 )	28 500	55 000	
PHSB 16	998	25.400 ( 1.0000 )	-12UNF ( 1.2500 )	69.85 ( 2.750 )	25.40 ( 1.000 )	34.93 ( 1.375 )	32.23 ( 1.269 )	139.70 ( 5.500 )	11.07 ( .436 )	104.78 ( 4.125 )	53.98 ( 2.125 )	38.10 ( 1.500 )	38.10 ( 1.500 )	44.45 ( 1.750 )	0.5 ( .020 )	47.625 ( 1 7/8 )	59 300	86 800	

Note<sup>(1)</sup> r<sub>s min</sub> stands for minimum allowable value of chamfer r.

Remark No grease is prepacked. Perform proper lubrication.

Inch series PILLOBALL Rod Ends **Insert Type/With Male Thread**

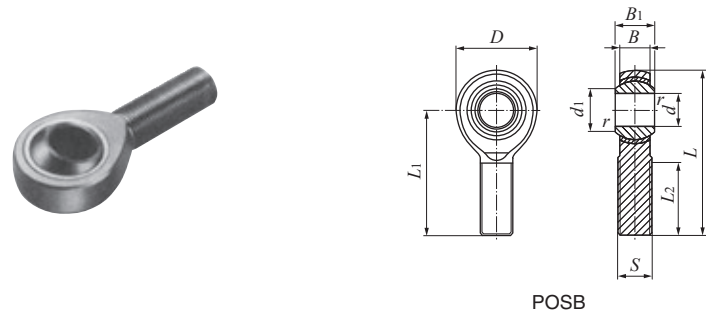

POSB

Identification number	Mass (Ref.) g	Boundary dimensions mm(inch)											Dynamic load capacity $C_d$ N	Static load capacity $C_s$ N
		$d$	Thread $S$ class 3A	$D$	$B$	$B_1$	$d_1$	$L$	$L_1$	$L_2$	$r_{s\min}^{(1)}$	Ball dia. mm (inch)		
POSB 2	5.4	3.175 (.1250)	-32UNC (.1380)	11.91 (.469)	4.75 (.187)	6.35 (.250)	4.75 (.187)	29.77 (1.172)	23.80 (.937)	12.70 (.500)	0.3 (.012)	7.938 ( $\frac{5}{16}$ )	1 850	2 160
POSB 2.5	9.1	3.967 (.1562)	-32UNC (.1640)	14.27 (.562)	5.56 (.219)	7.14 (.281)	6.32 (.249)	35.71 (1.406)	28.58 (1.125)	15.88 (.625)	0.3 (.012)	9.525 ( $\frac{3}{8}$ )	2 600	3 370
POSB 3	14	4.826 (.1900)	-32UNF (.1900)	15.88 (.625)	6.35 (.250)	7.92 (.312)	7.77 (.306)	39.70 (1.563)	31.75 (1.250)	19.05 (.750)	0.3 (.012)	11.112 ( $\frac{7}{16}$ )	3 460	4 850
POSB 4	23	6.350 (.2500)	-28UNF (.2500)	19.05 (.750)	7.14 (.281)	9.53 (.375)	9.02 (.355)	49.20 (1.937)	39.67 (1.562)	25.40 (1.000)	0.5 (.020)	13.097 ( $\frac{33}{64}$ )	4 590	8 870
POSB 5	36	7.938 (.3125)	-24UNF (.3125)	22.23 (.875)	8.74 (.344)	11.10 (.437)	11.35 (.447)	58.72 (2.312)	47.63 (1.875)	31.75 (1.250)	0.5 (.020)	15.875 ( $\frac{5}{8}$ )	6 800	14 200
POSB 6	54	9.525 (.3750)	-24UNF (.3750)	25.40 (1.000)	10.31 (.406)	12.70 (.500)	13.13 (.517)	61.93 (2.438)	49.23 (1.938)	31.75 (1.250)	0.5 (.020)	18.256 ( $\frac{23}{32}$ )	9 230	21 600
POSB 7	77	11.112 (.4375)	-20UNF (.4375)	28.58 (1.125)	11.10 (.437)	14.27 (.562)	14.88 (.586)	68.28 (2.688)	53.98 (2.125)	34.93 (1.375)	0.5 (.020)	20.638 ( $\frac{13}{16}$ )	11 200	26 100
POSB 8	122	12.700 (.5000)	-20UNF (.5000)	33.32 (1.312)	12.70 (.500)	15.88 (.625)	17.73 (.698)	78.59 (3.094)	61.93 (2.438)	38.10 (1.500)	0.5 (.020)	23.812 ( $\frac{15}{16}$ )	14 800	36 200
POSB 10	186	15.875 (.6250)	-18UNF (.6250)	38.10 (1.500)	14.27 (.562)	19.05 (.750)	21.31 (.839)	85.73 (3.375)	66.68 (2.625)	41.28 (1.625)	0.5 (.020)	28.575 ( $1\frac{1}{8}$ )	20 000	39 300
POSB 12	295	19.050 (.7500)	-16UNF (.7500)	44.45 (1.750)	17.45 (.687)	22.23 (.875)	24.84 (.978)	95.25 (3.750)	73.03 (2.875)	44.45 (1.750)	0.5 (.020)	33.338 ( $1\frac{3}{16}$ )	28 500	55 000
POSB 16	1 129	25.400 (1.0000)	-12UNF (1.2500)	69.85 (2.750)	25.40 (1.000)	34.93 (1.375)	32.23 (1.269)	139.70 (5.500)	104.78 (4.125)	53.98 (2.125)	0.5 (.020)	47.625 ( $1\frac{7}{8}$ )	59 300	112 000

Note<sup>(1)</sup>  $r_s$  min stands for minimum allowable value of chamfer  $r$ .  
Remark No grease is prepacked. Perform proper lubrication.

Lubrication Type PILLOBALL Rod Ends **Die-cast Type/With Female Thread**

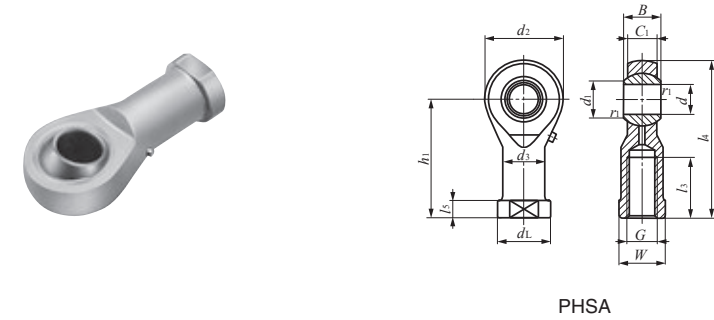

PHSA

Identification number	Mass (Ref.) g	Boundary dimensions mm															Ball dia. mm (inch)	Static load capacity $C_s$ N
		$d$	Thread $G$	$d_2$	$C_1$	$B$	$d_1$	$l_4$	$h_1$	$l_3$	$l_5$	$W$	$d_3$	$d_L$	$r_{1s\min}^{(1)}$			
PHSA 5	17	5	M 5×0.8	17	6	8	7.7	35.5	27	16	4	9	9	11	0.2	11.112 ( $\frac{7}{16}$ )	5 470	
PHSA 6	25	6	M 6×1	19.5	6.75	9	9	39.7	30	16	5	11	10	13	0.2	12.700 ( $\frac{1}{2}$ )	6 760	
PHSA 8	45	8	M 8×1.25	24	9	12	10.4	48	36	19	5	14	12.5	16	0.2	15.875 ( $\frac{5}{8}$ )	10 200	
PHSA 10	70	10	M10×1.5	28	10.5	14	12.9	57	43	23	6.5	17	15	19	0.2	19.050 ( $\frac{3}{4}$ )	13 100	
PHSA 12	105	12	M12×1.75	32	12	16	15.4	66	50	27	6.5	19	17.5	22	0.2	22.225 ( $\frac{7}{8}$ )	16 400	
PHSA 14	155	14	M14×2	36	13.5	19	16.9	75	57	30	8	22	20	25	0.3	25.400 (1)	20 000	
PHSA 16	190	16	M16×2	40	15	21	19.4	84	64	36	8	22	22	27	0.3	28.575 ( $1\frac{1}{8}$ )	23 900	
PHSA 18	290	18	M18×1.5	45	16.5	23	21.9	93.5	71	40	10	27	25	31	0.3	31.750 ( $1\frac{1}{4}$ )	28 800	
PHSA 20	400	20	M20×1.5	49	18	25	24.4	101.5	77	43	10	30	27.5	34	0.3	34.925 ( $1\frac{3}{8}$ )	33 400	
PHSA 22	500	22	M22×1.5	54	20	28	25.8	111	84	47	12	32	30	37	0.3	38.100 ( $1\frac{1}{2}$ )	40 400	

Note<sup>(1)</sup> Minimum allowable value of chamfer dimension  $r_1$ .  
Remarks1. A grease nipple is provided on the body.  
2. No grease is prepacked. Perform proper lubrication.  
3. When a metric fine thread specification for inner ring bore deameter  $d$  of 8 mm to 14 mm is required, please contact IKO.

Maintenance-free Type PILLOBALL Rod Ends **With Female Thread**

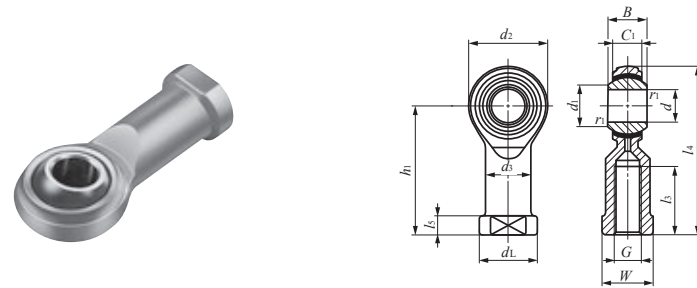

PHS...EC

Identification number	Mass (Ref.) g	Boundary dimensions mm														Dynamic load capacity $C_d$ N	Static load capacity $C_s$ N	
		$d$	Thread $G$	$d_2$	$C_1$	$B$	$d_1$	$l_4$	$h_1$	$l_3$	$l_5$	$W$	$d_3$	$d_L$	$r_{1smin}^{(1)}$			Ball dia. mm (inch)
PHS 3EC	5.7	3	M 3×0.5	12	4.5	6	5.2	27	21	10	3	5.5	5	6.5	0.2	7.938 ( $\frac{5}{16}$ )	3 500	2 480
PHS 4EC	11.9	4	M 4×0.7	14	5.3	7	6.5	31	24	12	4	8	8	9.5	0.2	9.525 ( $\frac{3}{8}$ )	4 950	3 260
PHS 5EC	16.5	5	M 5×0.8	16	6	8	7.7	35	27	12.5	4	9	9	11	0.2	11.112 ( $\frac{7}{16}$ )	6 540	4 010
PHS 6EC	25	6	M 6×1	18	6.75	9	9	39	30	13.5	5	11	10	13	0.2	12.700 ( $\frac{1}{2}$ )	8 410	4 940
PHS 8EC	43	8	M 8×1.25	22	9	12	10.4	47	36	16	5	14	12.5	16	0.2	15.875 ( $\frac{5}{8}$ )	14 000	7 760
PHS 10EC	72	10	M10×1.5	26	10.5	14	12.9	56	43	19.5	6.5	17	15	19	0.2	19.050 ( $\frac{3}{4}$ )	19 600	10 500
PHS 12EC	107	12	M12×1.75	30	12	16	15.4	65	50	24	6.5	19	17.5	22	0.2	22.225 ( $\frac{7}{8}$ )	26 200	13 700
PHS 14EC	160	14	M14×2	34	13.5	19	16.9	74	57	27	8	22	20	25	0.2	25.400 (1)	33 600	17 200
PHS 16EC	210	16	M16×2	38	15	21	19.4	83	64	33	8	22	22	27	0.2	28.575 ( $1\frac{1}{8}$ )	42 000	21 100
PHS 18EC	295	18	M18×1.5	42	16.5	23	21.9	92	71	36	10	27	25	31	0.2	31.750 ( $1\frac{1}{4}$ )	51 400	25 100
PHS 20EC	380	20	M20×1.5	46	18	25	24.4	100	77	40	10	30	27.5	34	0.2	34.925 ( $1\frac{3}{8}$ )	61 600	30 000
PHS 22EC	490	22	M22×1.5	50	20	28	25.8	109	84	41	12	32	30	37	0.2	38.100 ( $1\frac{1}{2}$ )	74 700	36 400

Note<sup>(1)</sup> Minimum allowable value of chamfer dimension  $r_1$   
 Remarks1. Neither oil hole nor grease nipple is provided.  
 2. When a metric fine thread specification for inner ring bore deameter  $d$  of 8 mm to 14 mm is required, please contact IKO.

Maintenance-free Type PILLOBALL Rod Ends **With Male Thread**

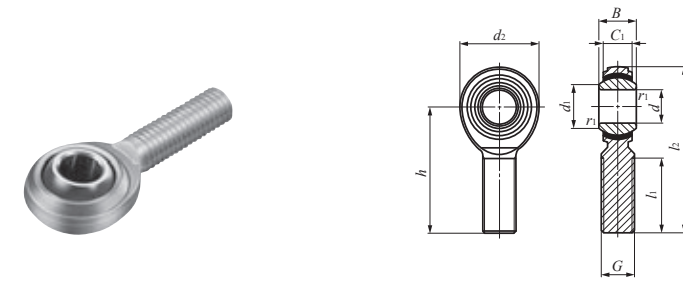

POS...EC

Identification number	Mass (Ref.) g	Boundary dimensions mm														Dynamic load capacity $C_d$ N	Static load capacity $C_s$ N
		$d$	Thread $G$	$d_2$	$C_1$	$B$	$d_1$	$l_2$	$h$	$l_1$	$r_{1smin}^{(1)}$	Ball dia. mm (inch)					
POS 3EC	5.0	3	M 3×0.5	12	4.5	6	5.2	33	27	15	0.2	7.938 ( $\frac{5}{16}$ )	3 500	1 220			
POS 4EC	8.1	4	M 4×0.7	14	5.3	7	6.5	37	30	17	0.2	9.525 ( $\frac{3}{8}$ )	4 950	2 060			
POS 5EC	12.5	5	M 5×0.8	16	6	8	7.7	41	33	20	0.2	11.112 ( $\frac{7}{16}$ )	6 540	3 340			
POS 6EC	19	6	M 6×1	18	6.75	9	9	45	36	22	0.2	12.700 ( $\frac{1}{2}$ )	8 410	4 730			
POS 8EC	32	8	M 8×1.25	22	9	12	10.4	53	42	25	0.2	15.875 ( $\frac{5}{8}$ )	14 000	7 760			
POS 10EC	54	10	M10×1.5	26	10.5	14	12.9	61	48	29	0.2	19.050 ( $\frac{3}{4}$ )	19 600	10 500			
POS 12EC	85	12	M12×1.75	30	12	16	15.4	69	54	33	0.2	22.225 ( $\frac{7}{8}$ )	26 200	13 700			
POS 14EC	126	14	M14×2	34	13.5	19	16.9	77	60	36	0.2	25.400 (1)	33 600	17 200			
POS 16EC	185	16	M16×2	38	15	21	19.4	85	66	40	0.2	28.575 ( $1\frac{1}{8}$ )	42 000	21 100			
POS 18EC	260	18	M18×1.5	42	16.5	23	21.9	93	72	44	0.2	31.750 ( $1\frac{1}{4}$ )	51 400	25 100			
POS 20EC	340	20	M20×1.5	46	18	25	24.4	101	78	47	0.2	34.925 ( $1\frac{3}{8}$ )	61 600	30 000			
POS 22EC	435	22	M22×1.5	50	20	28	25.8	109	84	51	0.2	38.100 ( $1\frac{1}{2}$ )	74 700	36 400			

Note<sup>(1)</sup> Minimum allowable value of chamfer dimension  $r_1$   
 Remarks1. Neither oil hole nor grease nipple is provided.  
 2. When a metric fine thread specification for inner ring bore deameter  $d$  of 8 mm to 14 mm is required, please contact IKO.



# L-BALLS

- L-Balls
- L-Ball Dust Cover



## Structure and Features

IKO L-Balls are self-aligning rod-ends consisting of a special zinc die-cast alloy body and a studded ball which has its axis at right angles to the body. They can perform tilting movement, oscillating movement and rotation with low torque, and transmit power smoothly due to uniform clearance between the sliding surfaces. Their superior wear resistance assures stable accuracy for long periods of time, and maintenance is simple. They are very economical bearings. For these reasons, they are widely used in link mechanisms in automobiles, construction machinery, farm and packaging machines, etc.

## Types

L-Balls are available in various types as shown in Table 1.

Table 1 Type of L-Balls

Type	L-Ball		L-Ball dust cover
	LHSA	LHS	PRC
Model code	LHSA	LHS	PRC

### L-Ball LHSA

These are compact rod-ends in which the spherical part of the ball-stud are held by the special zinc die-cast alloy body. There is a dust cover on the stud side and good quality lithium soap base grease is pre-packed. They can be run for long periods of time without re-lubrication and have excellent lubrication and anti-dust properties.

As shown in the structural drawing, these rod-ends are classified into 3 types by size. In addition, the ball-studs of LHSA 10 and lower are formed in one solid body, but those of LHSA 12 and higher, which are used under large loads, have the stud friction-welded to a high precision steel ball to give greater resistance to wear.

### L-Ball LHS

These rod-ends have a friction-welded ball-stud, and a special zinc die-cast alloy body which houses the spherical surface of the high precision steel ball. There is an almost complete contact across the sliding surfaces, and the uniform clearance guarantees a stable bearing life.

An L-Ball dust cover can be attached to these rod-ends. If the rod-ends are lubricated with lithium soap

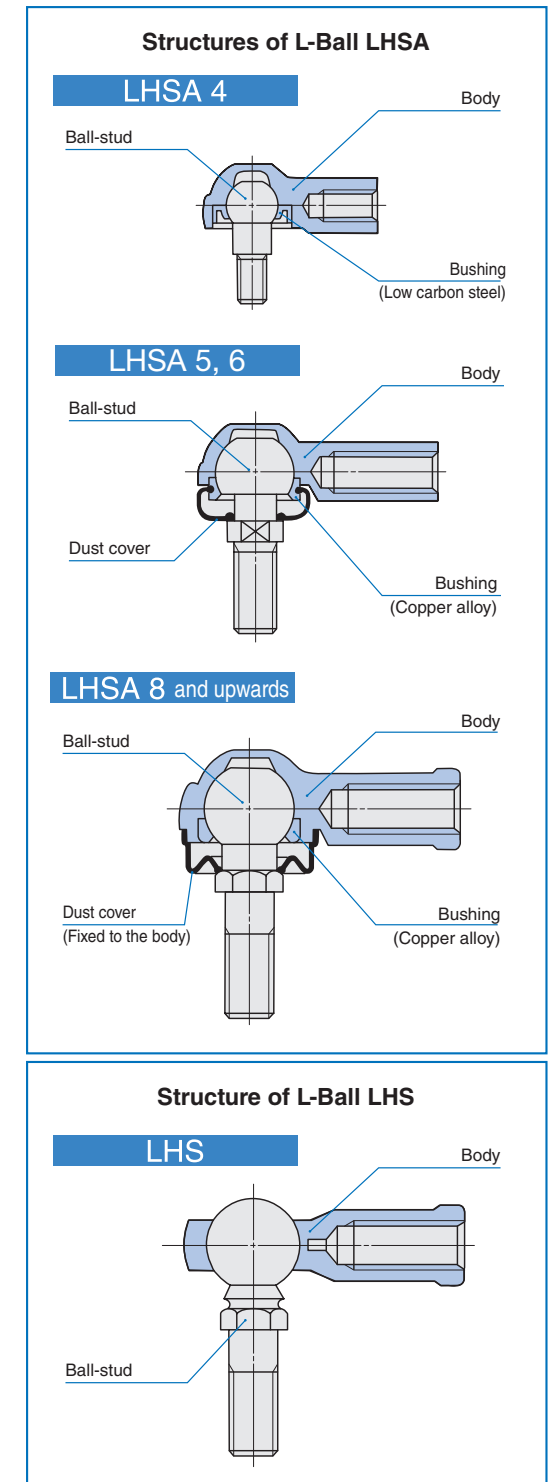

base grease, they have excellent lubrication and anti-dust properties and can run for long periods of time without re-lubrication. When the L-Ball LHS is delivered with a dust cover on request, lithium soap base grease is prepacked.



### L-Ball Dust Cover PRC

This is for the L-Ball LHS series. It is made of special synthetic rubber which has excellent resistance to oil and ozone. The cover offers very effective dust protection and prevents grease leakage.

### Identification Number

The identification number of L-Balls consists of a model code, a size and any supplemental codes as shown in the examples.

**Examples of identification number**

**Example 1 (Female thread of the body : In case of right-hand threaded)**

Model code: LHS, Size: 8

Type: LHS, Size of thread (M8): 8

**Example 2 (Female thread of the body : In case of left threaded)**

Model code: LHS, Size: 8, Supplemental code: L

Left-handed thread: L

**Example 3 (when a dust cover PRC is attached to LHS)**

Model code: LHS, Size: 8, Supplemental code: D

With dust cover: D

### Accuracy

The accuracy of L-Balls is shown in Table 2.

Table 2 Tolerance

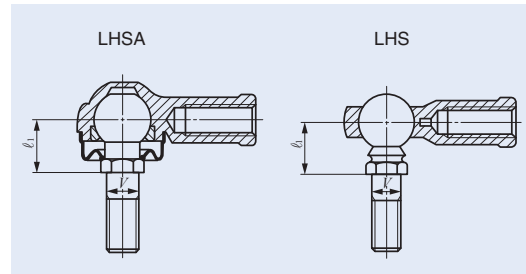

Type	Dimension symbol	Tolerance
LBSA	$l_1$	$\pm 0.5$
	$V$	0 - 0.2 <sup>(1)</sup>
LBS	$l_1$	$\pm 0.4$
	$V$	h9

unit: mm

Note<sup>(1)</sup> This dimensional tolerance applies to LBSA 5 and higher.

### Selection of L-Balls

The static load capacity and maximum operating load of L-Balls are determined in consideration of the strength of the ball stud and the body. Accordingly, L-Balls are selected on the basis of the static load capacity  $C_s$  shown in the dimension table and the maximum operating load shown in Table 3.

#### Static load capacity

The static load capacity  $C_s$  shown in the dimension table represents the allowable axial force  $F$  which is determined by the mechanical strength of the ball-stud at the section 'A' under the bending moment due to the force  $F$  as illustrated in Fig. 1. If  $F$  increases beyond the static load capacity, deformation will begin at A, leading to breakage.

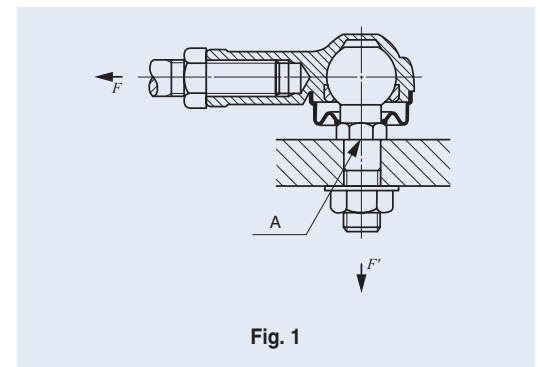

#### Maximum operating load

The strength of the body must also be taken into consideration when L-Balls are operated in a high-temperature or low-temperature atmosphere or receive repetitive loads of long duration or shock loads. A guideline for maximum operating load of L-Balls is shown in Table 3. When the fixing bolt in the main body is fixed and a load is applied in the direction of  $F'$ , the bending stress in the fixing bolt must be taken into consideration.

Table 3 Maximum operating load

Identification number	Maximum operating load	Identification number	Maximum operating load
LBSA 4	840	LBS 5	880
LBSA 5	1 180	LBS 6	1 080
LBSA 6	1 080	LBS 8	1 630
LBSA 8	1 900	LBS10	2 100
LBSA10	2 170	LBS12	2 620
LBSA10M	2 170	LBS14	3 190
LBSA12	2 790	LBS16	3 820
LBSA14	3 540	LBS18	4 610
—	—	LBS20	5 340
—	—	LBS22	6 460

unit: N

### Lubrication

LBSA is prepacked with lubricating grease ALVANIA GREASE S2 (Shell Lubricants Japan K.K.). LBS is not provided with prepacked grease. Perform proper lubrication.

Operating LBS without lubrication will increase the wear of the sliding contact surface or cause seizure.

### Operating Temperature Range

The maximum allowable temperature for L-Balls is +80°C.

### Precautions for Use

**1 Tightening depth**  
It is recommended that the tightening depth of the screw into the body is more than twice the nominal diameter of thread.

**2 Allowable tilting angle**  
The allowable tilting angle is shown in Table 4.

Table 4 Allowable tilting angle

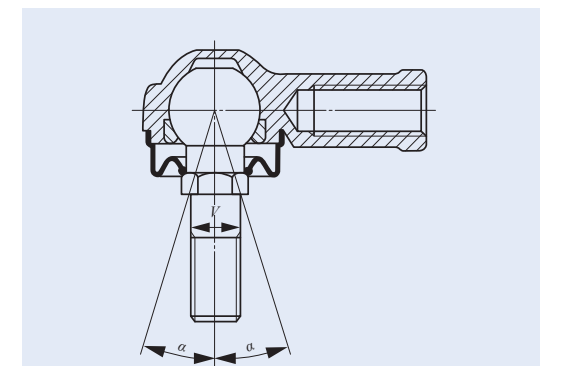

Nominal dia. mm	LBSA	LBS
$V$	$\alpha$	$\alpha$
4	15	—
5	17	15
6	17	17
8	18	18
10	19	19
12	19	19
14	20	20
16	—	20
18	—	21
20	—	20
22	—	21

unit: degree

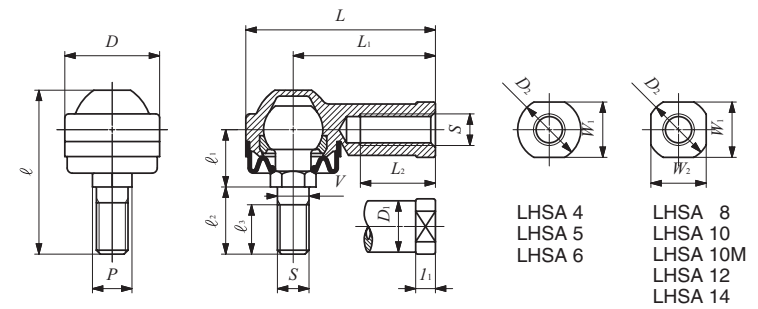
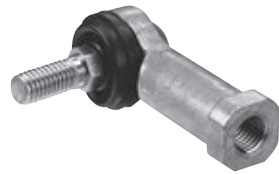

Identification number	Mass (Ref.) g	Boundary dimensions mm												
		Thread <i>S</i>	<i>V</i>	<i>D</i>	<i>L</i>	<i>L</i> <sub>1</sub>	<i>L</i> <sub>2</sub>	<i>l</i> <sub>1</sub>	<i>W</i> <sub>1</sub>	<i>W</i> <sub>2</sub>	<i>D</i> <sub>1</sub>	<i>D</i> <sub>2</sub>	<i>l</i>	<i>P</i>
LHSA 4	11	M 4×0.7	*4	14	25	18	8	4	8	—	8	10	19.5	*5.5
LHSA 5	27	M 5×0.8	5	17	38.5	30	16	5	10	—	10	12	32.5	8
LHSA 6	27	M 6×1	6	19	39.5	30	16	5	10	—	10	12	32.5	8
LHSA 8	64	M 8×1.25	8	24	48	36	19	5	14	14	13	16	41.5	10
LHSA 10	106	M10×1.25	10	28	57	43	23	6.5	17	17	15	19	49	12
LHSA 10M	106	M10×1.5	10	28	57	43	23	6.5	17	17	15	19	49	12
LHSA 12	180	M12×1.75	12	34	67	50	27	6.5	19	19	17.5	22	64	14
LHSA 14	260	M14×2	14	38	76	57	30	8	22	22	20	25	72	17

<i>l</i> <sub>1</sub>	<i>l</i> <sub>2</sub>	<i>l</i> <sub>3</sub>	Ball dia.	Static load capacity
				<i>C</i> <sub>s</sub> N
7	7	5	8	880
12	13	10	11.112	1 180
12	13	10	11.112	1 670
14.5	17	12.5	15	4 380
16	21	17	19.05	7 400
16	21	17	19.05	7 400
20	30	20	22.225	9 900
22.5	33.5	22	25.4	14 600

Remarks1. The item marked \* is manufactured with a neck diameter of  $\phi 3.4$ . The item marked \* is manufactured with a diameter of  $\phi 5.5$  instead of a width across flats.  
 2. Provided with prepacked grease.

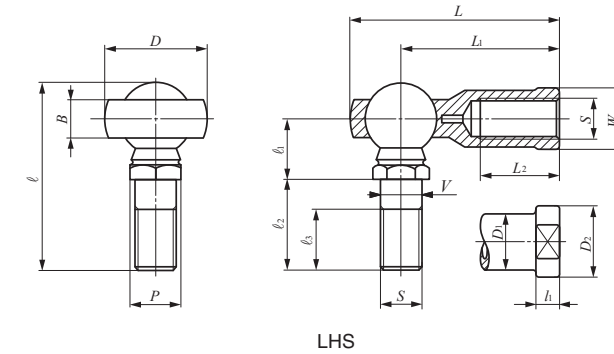

Identification number	Mass (Ref.) g	Thread S	Boundary dimensions mm											
			V	D	B	L	L <sub>1</sub>	L <sub>2</sub>	l <sub>1</sub>	W	D <sub>1</sub>	D <sub>2</sub>	l	P
<b>LHS 5</b>	22	M 5×0.8	5	17	6	35.5	27	16	4	9	9	11	30.5	8
<b>LHS 6</b>	32	M 6×1	6	19.5	6.75	39.7	30	16	5	11	10	13	36.5	10
<b>LHS 8</b>	60	M 8×1.25	8	24	9	48	36	19	5	14	12.5	16	44	11
<b>LHS 10</b>	102	M10×1.5	10	28	10.5	57	43	23	6.5	17	15	19	52.5	13
<b>LHS 12</b>	160	M12×1.75	12	32	12	66	50	27	6.5	19	17.5	22	61	17
<b>LHS 14</b>	227	M14×2	14	36	13.5	75	57	30	8	22	20	25	69	17
<b>LHS 16</b>	300	M16×2	16	40	15	84	64	36	8	22	22	27	74	19
<b>LHS 18</b>	445	M18×1.5	18	45	16.5	93.5	71	40	10	27	25	31	84	22
<b>LHS 20</b>	580	M20×1.5	20	49	18	101.5	77	43	10	30	27.5	34	90.5	24
<b>LHS 22</b>	765	M22×1.5	22	54	20	111	84	47	12	32	30	37	99	27

Remark No grease is prepacked. Perform proper lubrication.

l <sub>1</sub>	l <sub>2</sub>	l <sub>3</sub>	Ball dia.	Static load capacity
				C <sub>s</sub> N
10	15	11	11.112	2 080
11.5	18.5	14	12.7	3 290
14.5	21.5	15	15.875	4 900
17	26	18	19.05	7 640
20	30	20	22.225	12 400
22.5	33.5	22	25.4	14 600
24.5	35.5	23	28.575	19 500
27.5	40.5	25	31.75	25 600
30	43	27	34.925	31 600
32.5	47.5	30	38.1	39 800

**L-BALL**

L-Ball Dust Cover

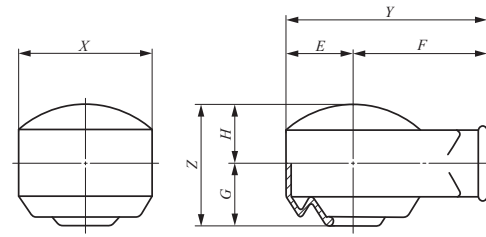

PRC

Identification number	Boundary dimensions mm						
	<i>X</i>	<i>Y</i>	<i>E</i>	<i>F</i>	<i>Z</i>	<i>G</i>	<i>H</i>
<b>PRC 5</b>	20	29	10	19	16	8	8
<b>PRC 6</b>	22	31	11	20	19	9.5	9.5
<b>PRC 8</b>	27	38.5	13.5	25	24	12	12
<b>PRC 10</b>	31	45.5	15.5	30	27	14	13
<b>PRC 12</b>	36	53	18	35	32	16.5	15.5
<b>PRC 14</b>	40	60	20	40	36.5	19	17.5
<b>PRC 16</b>	44	68	22	46	40	20.5	19.5
<b>PRC 18</b>	49	74.5	24.5	50	46	23.5	22.5
<b>PRC 20</b>	54	82	27	55	50	25.5	24.5
<b>PRC 22</b>	59	89.5	29.5	60	53.5	27.5	26



**K**

LHSA  
LHS

# SUPER FLEXIBLE NOZZLES



## Structure and Features

IKO Super Flexible Nozzle is a compact nozzle for use on a machine tool to supply and spray cutting oil exactly at the required positions.

The angle of the nozzle can be changed easily and freely. Therefore, oil supply can be concentrated upon the working area, and cooling and lubrication can be performed effectively. As a result, cutting resistance is reduced and superior finish is obtained, achieving high machining accuracy. Also, tool life is longer.

The Super Flexible Nozzle is used in many places such as at the spindle end of Machining Center and at the tool holder of N/C lathe.

The features of Super Flexible Nozzle are as follows.

- ① A spherical bushing is incorporated to adjust the tilting angle of nozzle easily.
- ② The Super Flexible Nozzle is compact in size, and the design on parts around the spindle and tool can be made simple.
- ③ The nozzle length is short, and winding of cutting chips around the nozzle will not occur.
- ④ By using a number of Super Flexible Nozzles, cutting oil can be supplied and cutting chips can be removed more effectively.
- ⑤ The press fitting type and screw fitting type are available. The press fitting type is economical.

### Structures of Super Flexible Nozzles

#### SNA [Without nozzle]

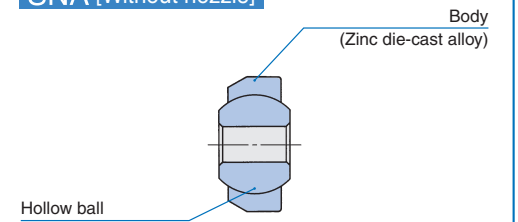

#### SNA [With nozzle]

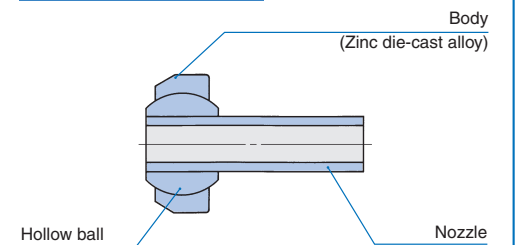

#### SNM

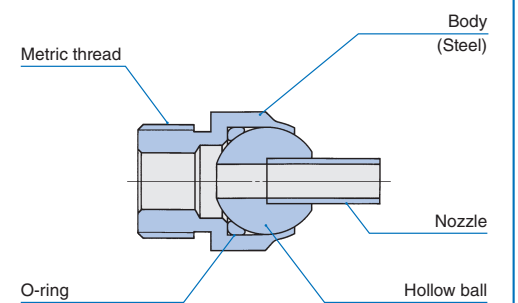

#### SNPT

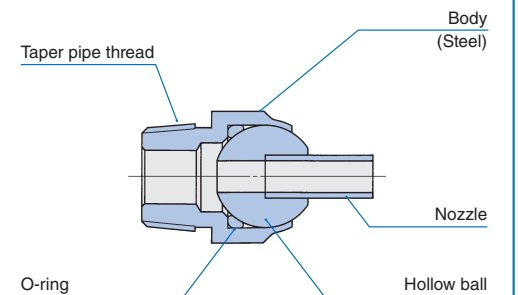



## Types

Super Flexible Nozzles shown in Table 1 are available.

Table 1 Type of Super Flexible Nozzle

Type		Model code
Press fitting type	Without nozzle	SNA
	With nozzle	
Screw fitting type	With metric threads	SNM
	With taper pipe threads	SNPT

## Identification Number

The identification number of Super Flexible Nozzle consists of a model code and a size. An example is shown as follows.

**Example of identification number**

Model code	Size
SNM	10-20

Type of nozzle: SNM

Nozzle bore or thread size: (M10×1.25)

Dimension from shoulder surface to nozzle top:※ (20mm)

※ In case of press fitting type without nozzle, this dimension is not indicated.

## Precautions for Use

When the press fitting type Super Flexible Nozzle is used, a  $\phi 15$  (H8)  $^{+0.027}_0$  bore for fitting hole must be prepared and fitting is made from the 30° chamfered end of the outer body. In this case, the body portion should be pushed for press fitting.

When the screw fitting type Super Flexible Nozzle is used and prevention of oil leakage from the fitting part is required, it is recommended to wind sealing tape on the thread portion or use rubber packing for the shoulder face of the outer body.

The direction of lubrication can be adjusted by inserting a screwdriver, etc. in the bore of the nozzle.

## Special Specifications

Super Flexible Nozzles with special length are also available. In this case, specify the necessary nozzle length in units of 1 mm, but do not exceed the maximum length shown in the dimension table as "L".

Super Flexible Nozzles with curved nozzle end or with special bore diameter are also available. In this case, please contact IKO by preparing a drawing or sketch with necessary specifications.

## SUPER FLEXIBLE NOZZLE

### Press Fitting Type Without Nozzle

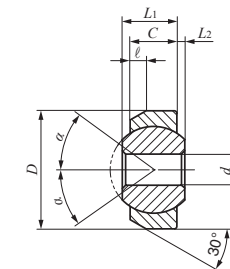

SNA

Identification number	Boundary dimensions mm						Ball dia. mm (inch)	Allowable tilting angle $\alpha$ degree
	d	D	L <sub>1</sub>	L <sub>2</sub>	C	$\ell$		
SNA 4	4	15	7	1	6	2	11.112 (7/16)	36
SNA 6	6							24

### Press Fitting Type With Nozzle

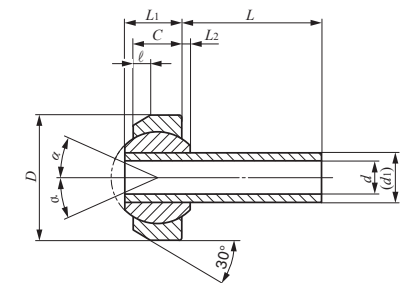
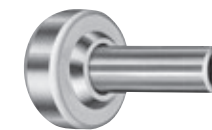

SNA

Identification number	Boundary dimensions mm									Ball dia. mm (inch)	Allowable tilting angle $\alpha$ degree	
	d	D	L			L <sub>1</sub>	L <sub>2</sub>	C	$\ell$			d <sub>1</sub>
SNA 3-L	3	15	6	15	32	7	1	6	2	6	11.112 (7/16)	24
SNA 4-L	4		6	16	40							

**SUPER FLEXIBLE NOZZLE**

Screw Fitting Type

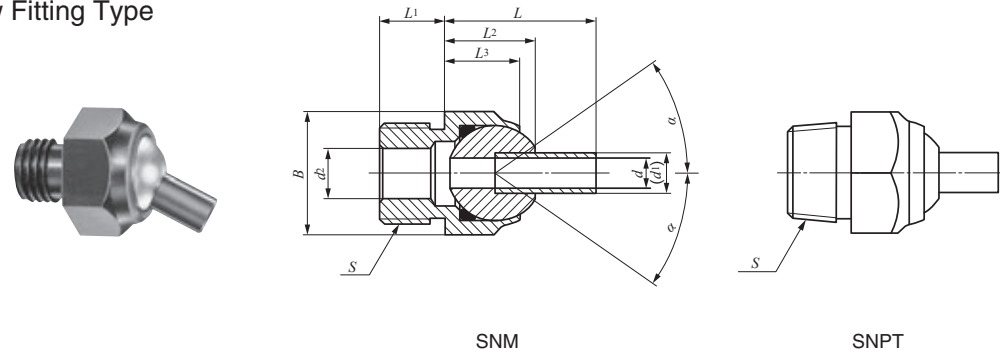

Identification number	Boundary dimensions mm										Ball dia. mm (inch)	Allowable tilting angle $\alpha$ degree		
	$d$	Thread $S$	$L$	$L_1$	$L_2$	$L_3$	$d_1$	$d_2$	Width across flats $B$	Width across corners (Ref.)				
<b>SNM 10-L</b>	4	M10×1.25	20	40	60	9	13	10.5	6	6	17	19.6	35	
<b>SNPT 1/4-L</b>		PT 1/4										12.700 ( $\frac{1}{2}$ )		
<b>SNM 20-L</b>	6	M20×1.5	30	50	70	13	18	15	8	10	24	27.7		
<b>SNPT 3/8-L</b>		PT 3/8										19.050 ( $\frac{3}{4}$ )		
<b>SNM 24-L</b>	8	M24×2.0	40	60	80	18	23	19	10	12	32	37		25.400 (1 )
<b>SNPT 1/2-L</b>		PT 1/2												

**PARTS FOR NEEDLE ROLLER BEARINGS**

- Seals for Needle Roller Bearings
- Cir-clips for Needle Roller Bearings
- Needle Rollers

